

REVISIONS					
NO.	DATE	ECN #	REMARKS	BY	APPD.

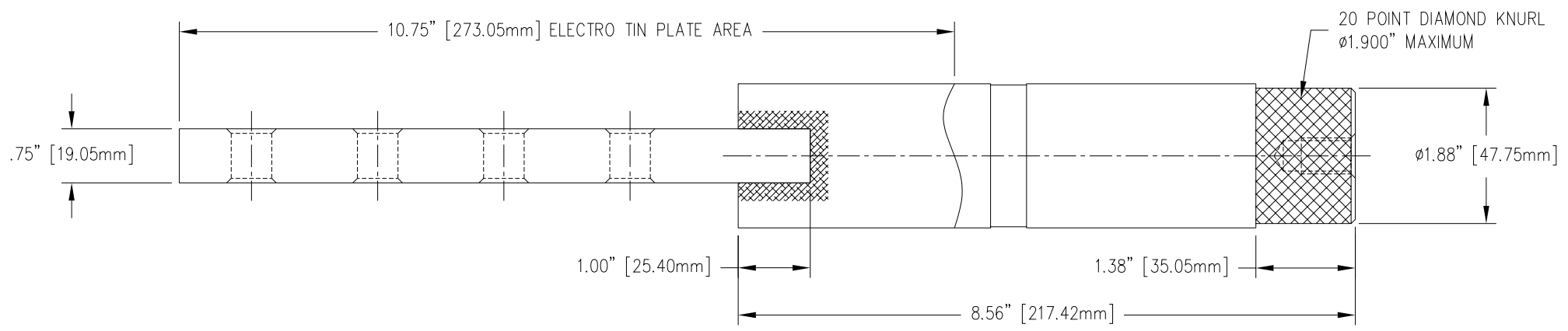
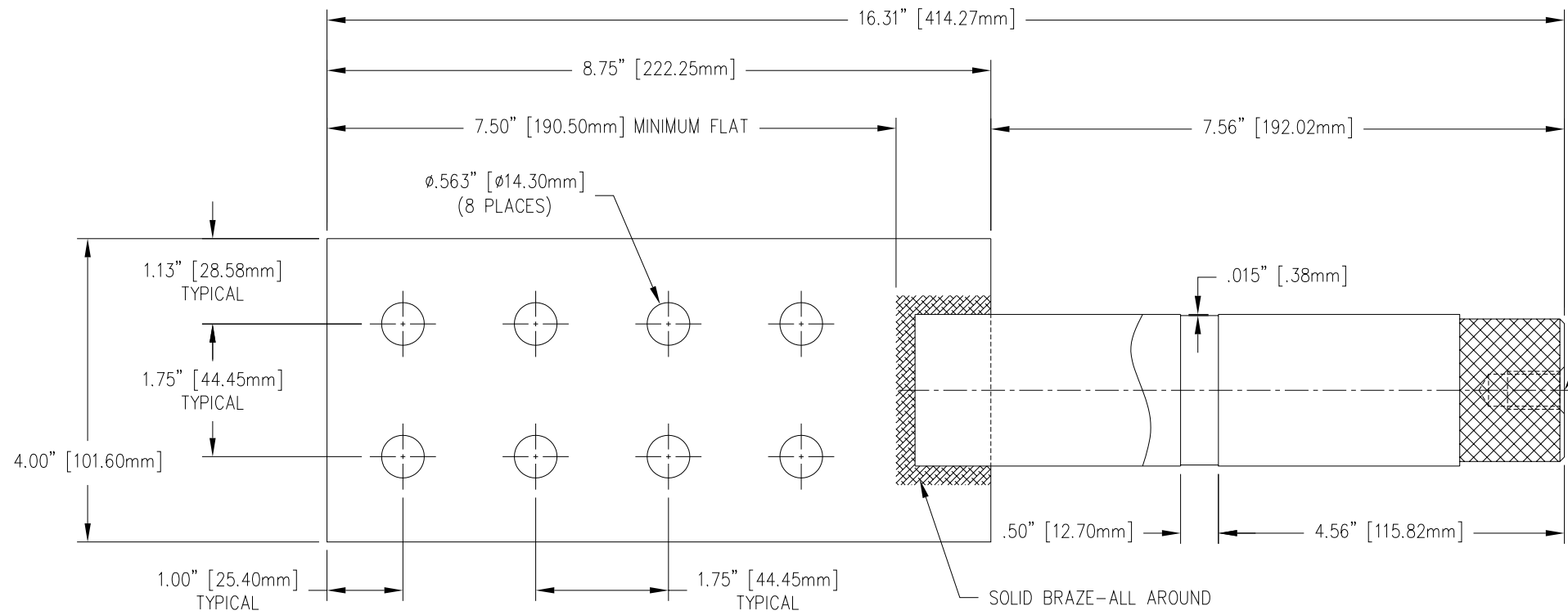

TOLERANCES
(EXCEPT AS NOTED)

DECIMAL
.XX = ±.050"
.XXX = ±.010"

ANGULAR
± 2°



H-J ENTERPRISES, INC.
3010 HIGH RIDGE BLVD. HIGH RIDGE, MO. 63049 USA
PHONE 1-636-677-3421 FAX 1-636-376-1915

**FABRICATED STUD
AND SPADE ASSEMBLY**

MATERIAL COPPER CDA 110 TIN PLATED

CHK'D APP'D DRAWING NO.
SCALE N.T.S.

FS8009-001

DRAWN BY CJT DATE 1-10-01