

REVISIONS				
NO.	DATE	REMARKS	BY	APPD.
1	12-2-99	EDITED TAP DEPTH AND DIMENSIONS.	CJT	LHE

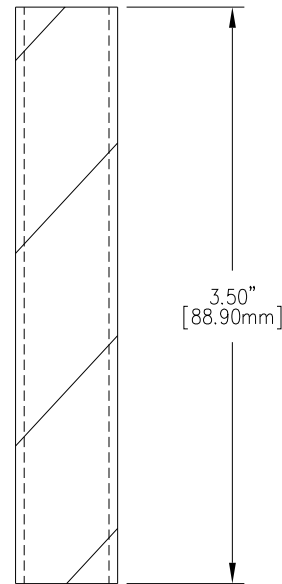

THREAD PROTECTOR

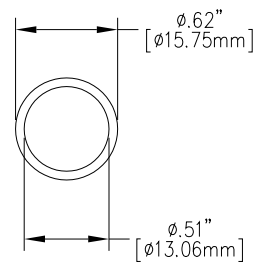
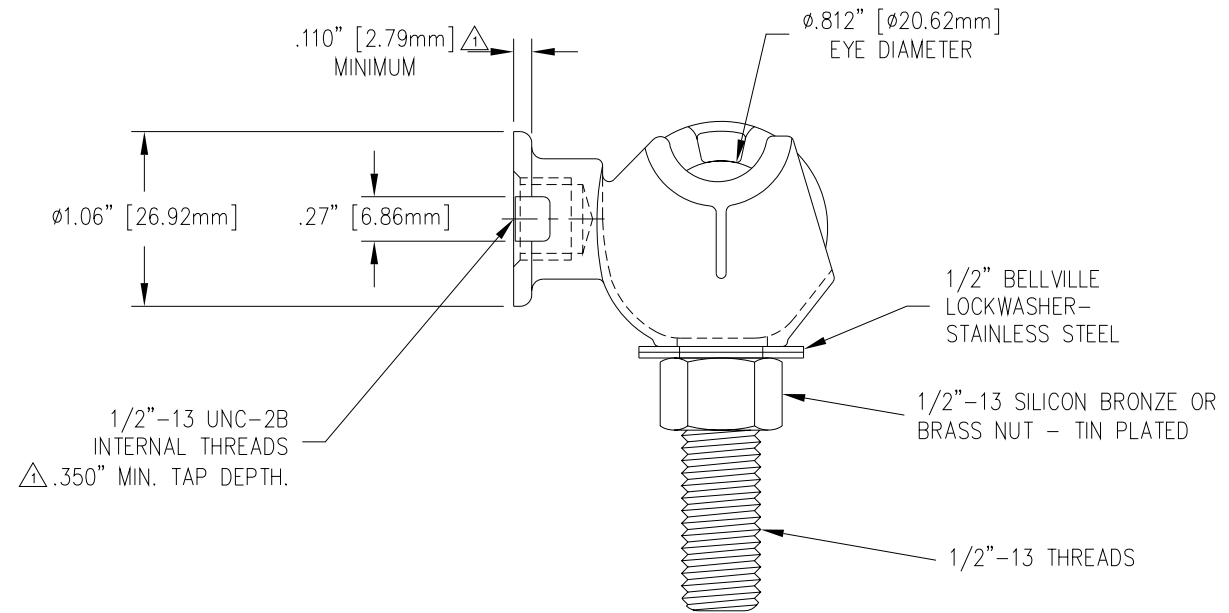
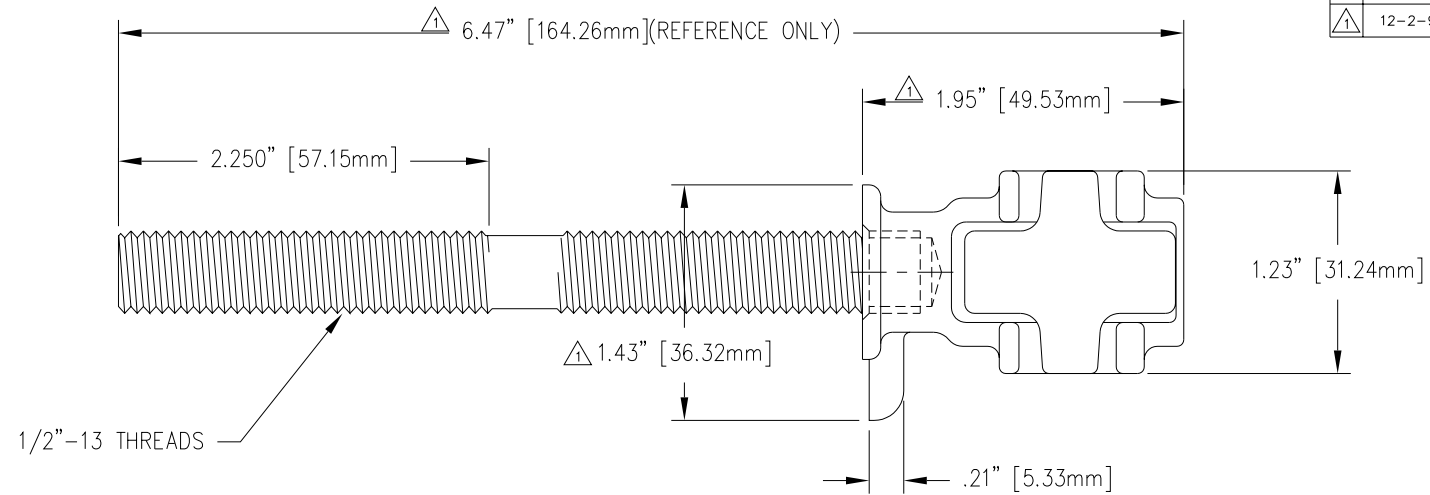

MATERIAL:  
 TERMINAL BODY - CDA 844-TIN PLATED  
 EYEBOLT - CDA 955-TIN PLATED  
 STUD - CDA 110

TOLERANCES (EXCEPT AS NOTED) DECIMAL $\pm .032" / .8mm$ FRACTIONAL $\pm$ ANGULAR $\pm 2^\circ$		<b>H-J ENTERPRISES, INC.</b> 3010 HIGH RIDGE BLVD, HIGH RIDGE, MO. 63049 USA PHONE 1-636-677-3421 FAX 1-636-376-1915		
		50 KVA EYEBOLT & STUD HARDWARE ASSEMBLY		
		MATERIAL (SEE DRAWING)		
		CHK'D DATE	APP'D DATE	DRAWING NO. AS1019-016
DRAWN BY CJT	DATE 10-01-98	SCALE N.T.S.		