

REVISIONS					
NO.	DATE	ECN #	REMARKS	BY	APPD.
1	12-6-99		ADDED TAP NOTE AND REDIMENSIONED DRAWING.	CJT	LHE
2	4-11-05	HJ05-026	THREADS WERE 2.375"	CJT	SP

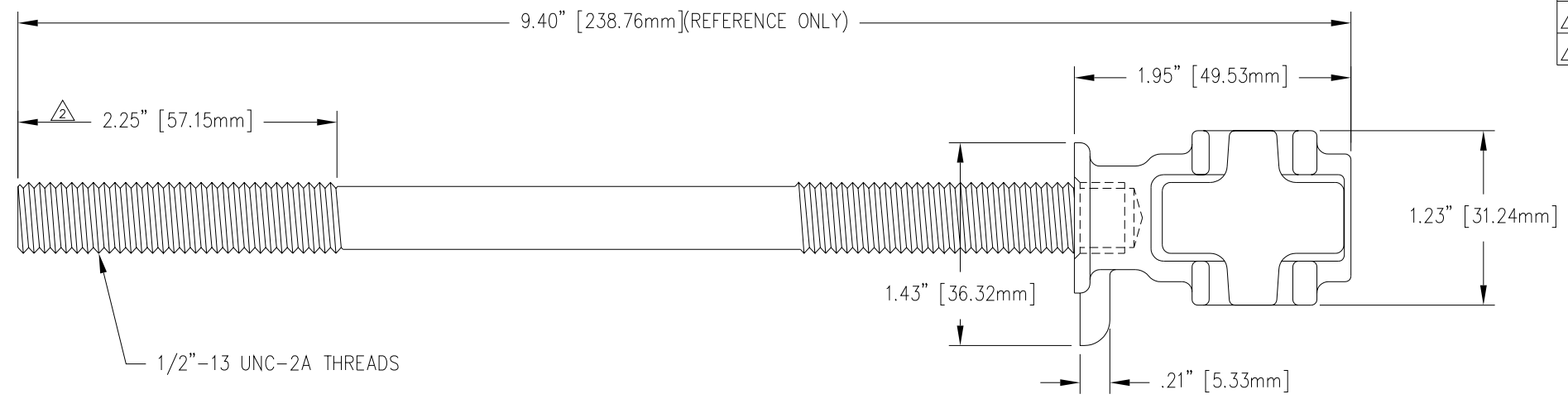

1/2"-13 UNC-2A THREADS

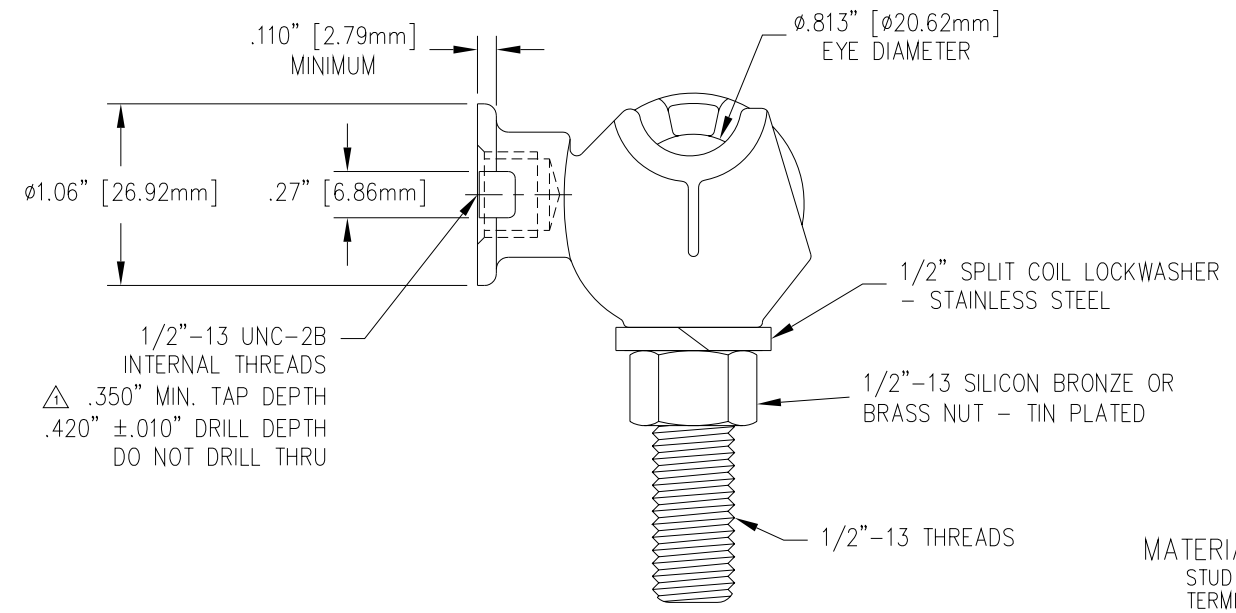

1/2"-13 UNC-2B
INTERNAL THREADS
1 .350" MIN. TAP DEPTH
.420" ±.010" DRILL DEPTH
DO NOT DRILL THRU

MATERIAL:
STUD - COPPER CDA 11000
TERMINAL BODY - CDA 84400 TIN PLATED
EYEBOLT - CDA 95500 TIN PLATED

NOTE:
STUD HAS BEEN REMOVED
IN THIS VIEW FOR CLAIRITY.

TOLERANCES (EXCEPT AS NOTED) DECIMAL ± .032"/.8mm FRACTIONAL ± ANGULAR ± 2°		H-J ENTERPRISES, INC. 3010 HIGH RIDGE BLVD. HIGH RIDGE, MO. 63049 USA PHONE 1-636-677-3421 FAX 1-636-376-1915	
		50 KVA TERMINAL BODY, EYEBOLT, AND STUD HARDWARE ASSEMBLY	
		MATERIAL (SEE ABOVE)	
		CHK'D DRAWN BY CJT	APP'D DATE 10-5-98