

REVISIONS					
REV.	DATE	ECN #	DESCRIPTION	BY	APP'D
1	8/17/99		CHG'D TAP DEPTH	CJT	LHE
2	5/08/00		ADDED CHAMFER	CJT	LHE
3	10/29/15		CORRECTED DIM PER -844. ADDED DATUM -A-. ADDED NOTE. SW REDRAW	TJF	BLB
4	11/15/2016	HJ16-235	CHG'D DIM, WAS 3.50"[88.9mm]-TO-3.504[89mm]	TJF	BLB
5	5/10/2018	HJ18-087	ADD A "MIN" TOLERANCE TO .25" THICKNESS DIM	TJF	LO

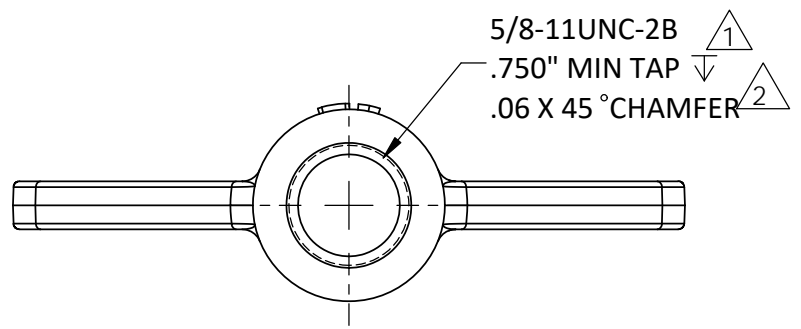
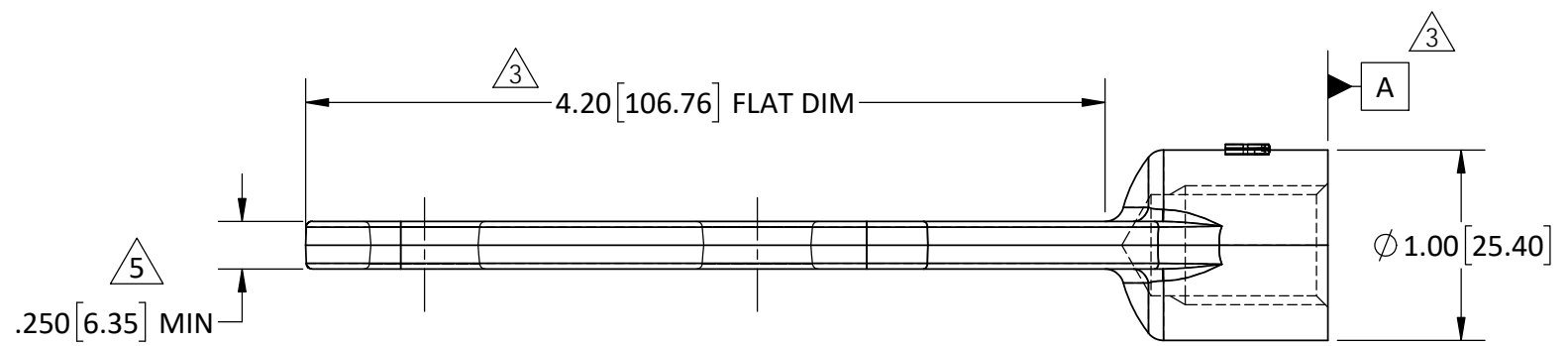
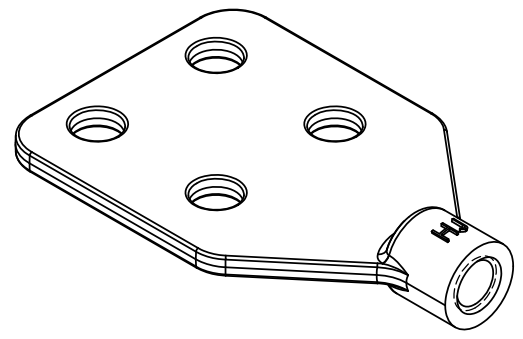
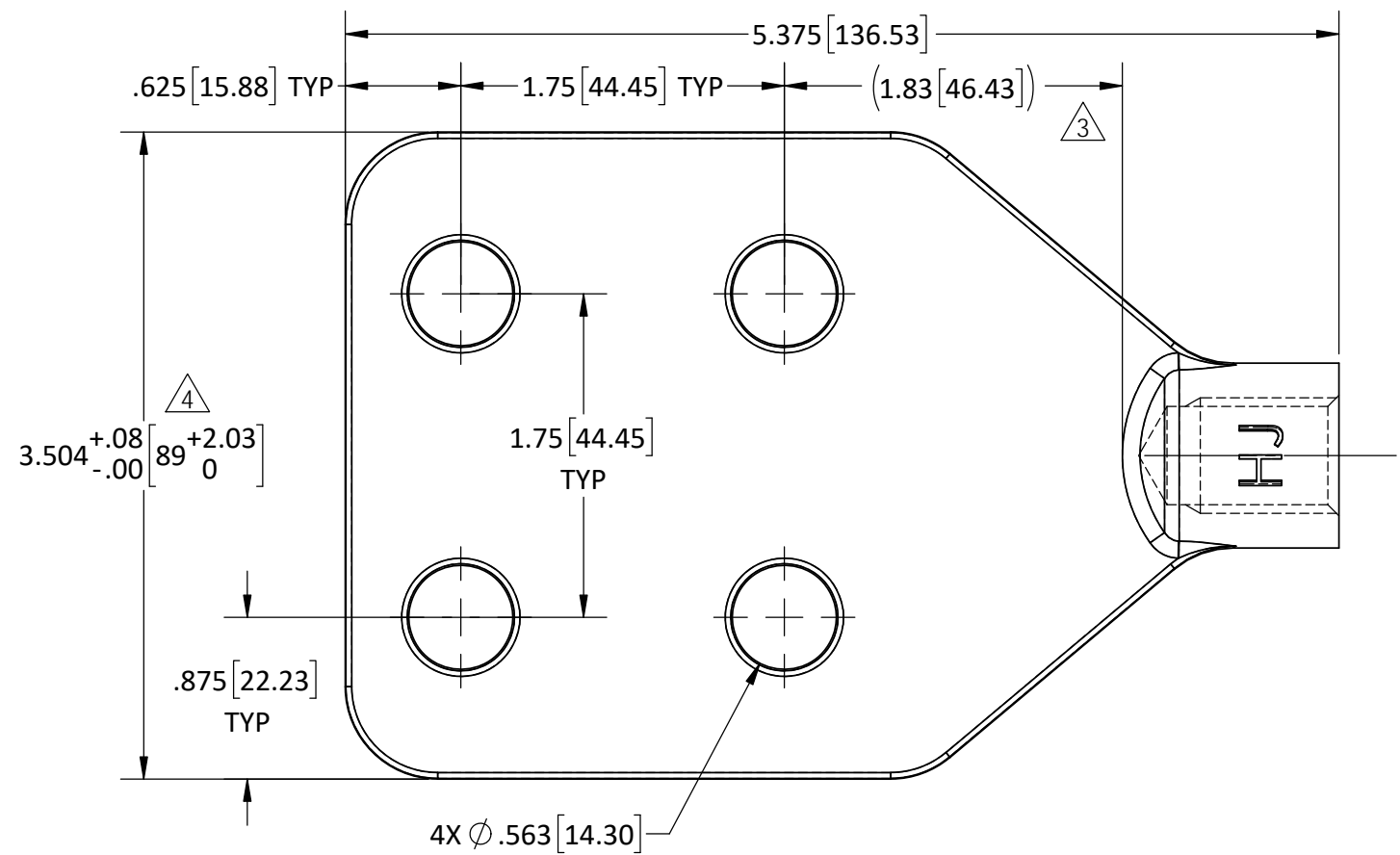
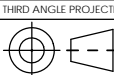

NOTE:
 1. FULL THREADS FROM SURFACE **A** TO THE DEPTH SPECIFIED IN THE TAP NOTE

THIRD ANGLE PROJECTION

 PROPRIETARY AND CONFIDENTIAL
 THE INFORMATION CONTAINED IN THIS DRAWING IS THE SOLE PROPERTY OF H-J ENTERPRISES, INC. ANY REPRODUCTION IN PART OR AS A WHOLE WITHOUT THE WRITTEN PERMISSION OF H-J ENTERPRISES, INC. IS PROHIBITED.
 REMOVE ALL BURRS & SHARP EDGES

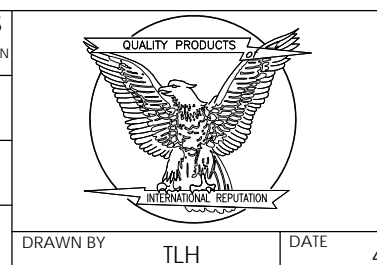
TOLERANCES
 (EXCEPT AS NOTED) DIMENSIONS ARE SHOWN IN: in/mm
 DECIMAL ±.032/.8mm
 FRACTIONAL ±
 ANGULAR ±2°



H-J ENTERPRISES, INC.
 3010 HIGH RIDGE BLVD. HIGH RIDGE, MO. 63049 USA
 PHONE 1-636-677-3421 FAX 1-636-376-1915
SPADE, 4H, 3.5"W X 1/4"THK, W/ 5/8-11 THRDS
 MATERIAL CDA 84400 - TIN PLATED
 CHK'D - APP'D - DRAWING NO. SP3022-001
 SCALE N.T.S.
 DRAWN BY TLH DATE 4/04/96

3