

REVISIONS					
REV.	DATE	ECN #	DESCRIPTION	BY	APP'D
1	5/29/2018		CHG'D DIM TO REF. SW REDRAW	TJF	CJT

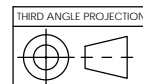
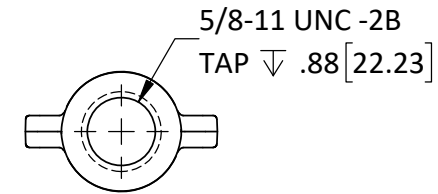
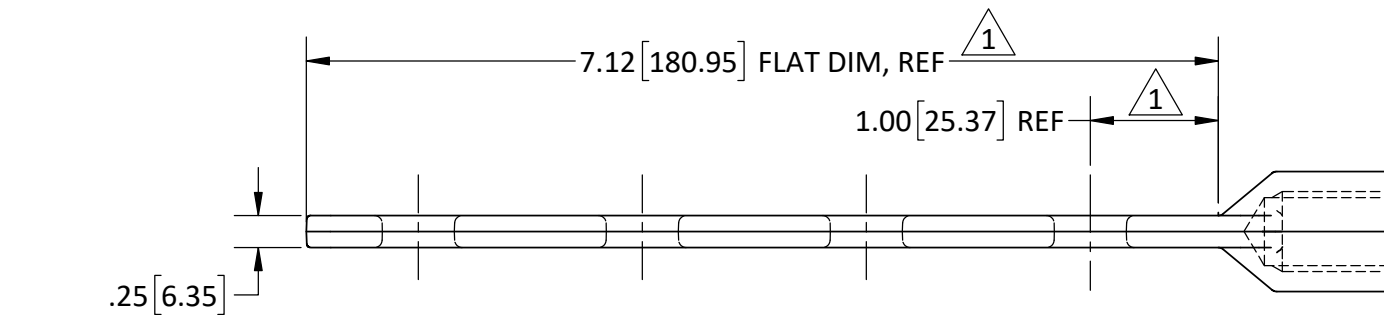
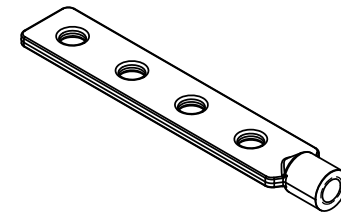
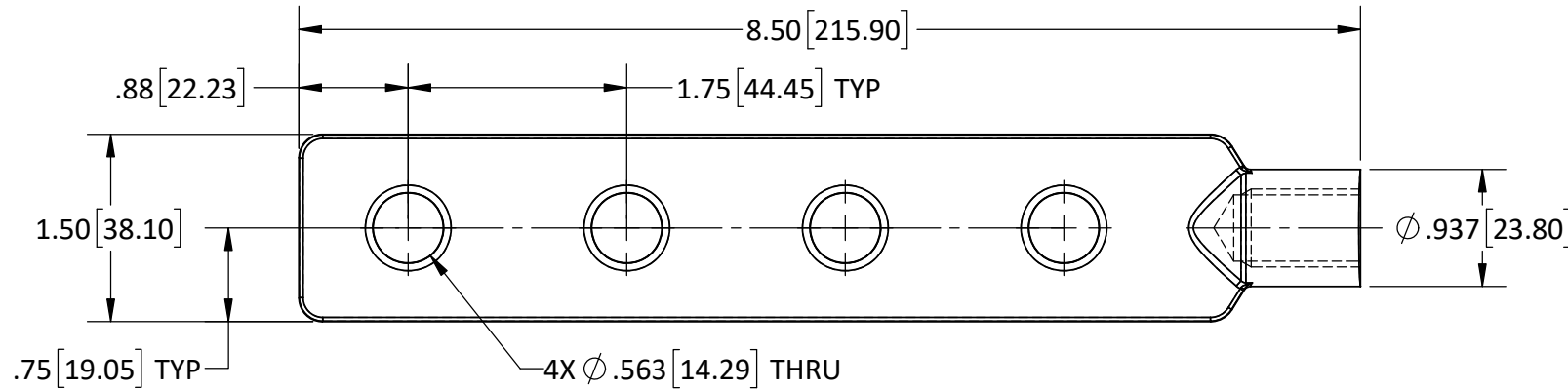

TOLERANCES
(EXCEPT AS NOTED)
ALL DIMENSIONS ARE
IN: in/mm

DECIMAL
± .032"/.8mm

FRACTIONAL
±

ANGULAR
± 2°

PROPRIETARY AND CONFIDENTIAL
THE INFORMATION CONTAINED IN THIS
DRAWING IS THE SOLE PROPERTY OF
H-J ENTERPRISES, INC. ANY
REPRODUCTION IN PART OR AS A WHOLE
WITHOUT THE WRITTEN PERMISSION OF
H-J ENTERPRISES, INC. IS PROHIBITED.

REMOVE ALL BURRS & SHARP EDGES



H-J ENTERPRISES, INC.
3010 HIGH RIDGE BLVD. HIGH RIDGE, MO. 63049 USA
PHONE 1-636-677-3421 FAX 1-636-376-1915

SPADE, 4H, INLINE, 1.50"W, 5/8-11 THRD

MATERIAL CDA 84400 - TIN PLATED

CHK'D APP'D SCALE N.T.S.

DRAWING NO.
SP3020-001

DRAWN BY TLH DATE 4/08/96