

| REVISIONS |          |          |               |    |          |
|-----------|----------|----------|---------------|----|----------|
| REV.      | DATE     | ECN #    | DESCRIPTION   | BY | APPROVED |
| 1         | 2/3/2014 | HJ14-016 | ADDED NOTE 2. | BS | BLB      |

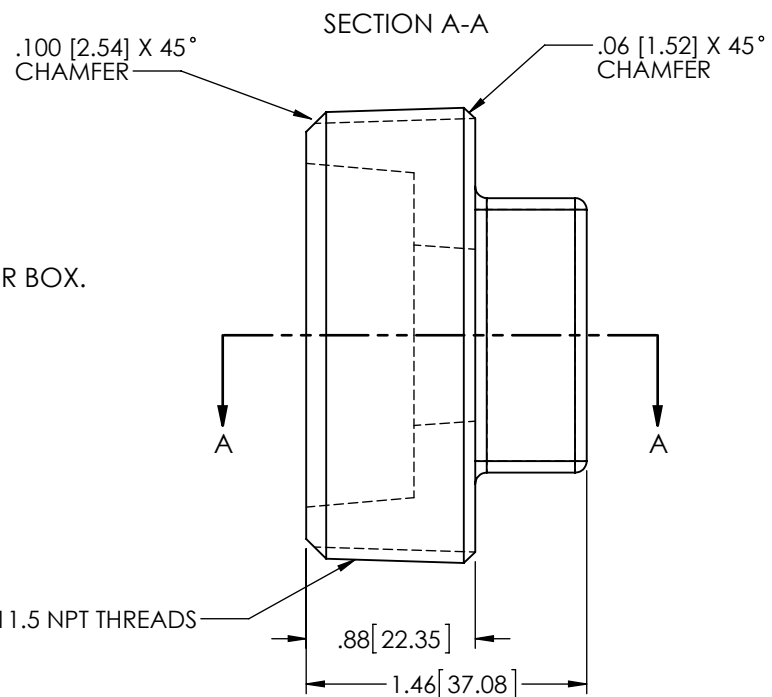

NOTE:  
1. PACKAGED 120 PER BOX.

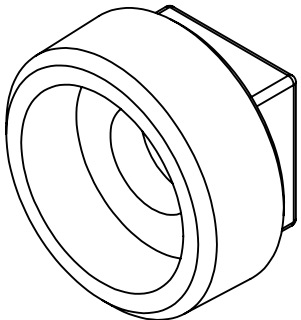
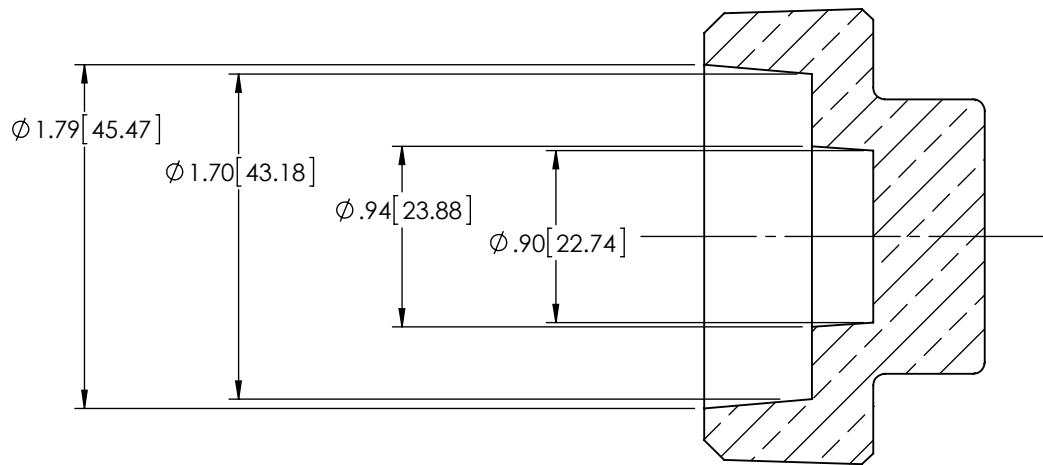
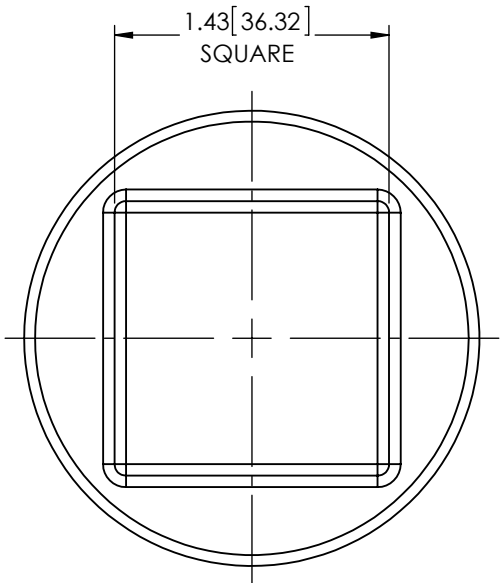

2" - 11.5 NPT THREADS

NOTE:  
1. ALL FILLETS AND ROUNDS R.03 [.76], UNLESS OTHERWISE NOTED.  
2. PACKAGED 45 PER BOX.

**PROPRIETARY AND CONFIDENTIAL**  
THE INFORMATION CONTAINED IN THIS DRAWING IS THE SOLE PROPERTY OF H-J INTERNATIONAL, INC. ANY REPRODUCTION IN PART OR AS A WHOLE WITHOUT THE WRITTEN PERMISSION OF H-J INTERNATIONAL, INC. IS PROHIBITED.

TOLERANCES  
(EXCEPT AS NOTED)

DECIMAL  
+/- .032"/.8mm  
FRACTIONAL  
+/-  
ANGULAR  
+/- 2 Degrees



H - J INTERNATIONAL, INC.  
3010 HIGH RIDGE BLVD. HIGH RIDGE, MO. 63049 USA  
PHONE 1-636-677-3421 FAX 1-636-376-1915

2"-11.5 NPT PIPE PLUG

MATERIAL 316 STAINLESS STEEL

CHK'D CJT APP'D 2/3/14  
SCALE N.T.S.

DRAWING NO.  
PG6035-002

DRAWN BY CMH DATE 2-17-11