

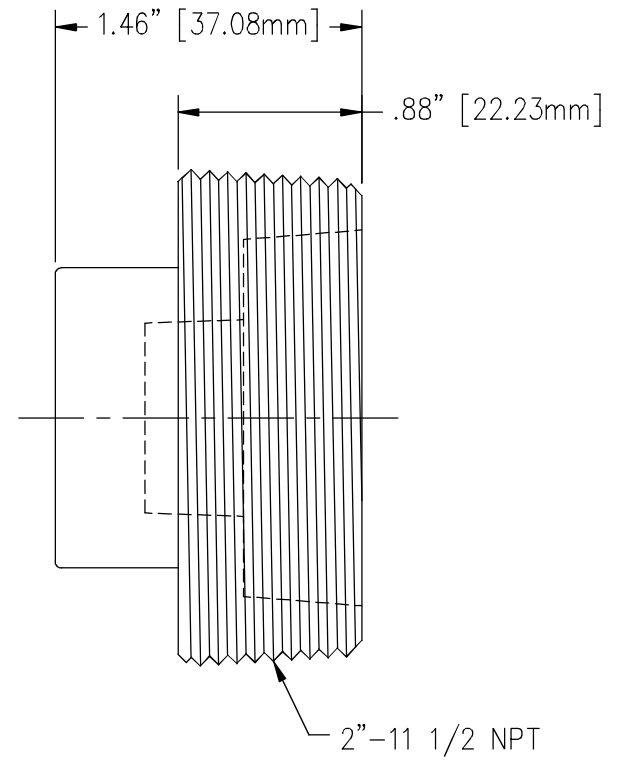

REVISIONS					
NO.	DATE	ECN #	REMARKS	BY	APPD.
△	3/14/2013	HJ13-059	ADDED ALTERNATE MATERIALS HPb59-1 AND HPb58-3.	BS	ABB
△	2/4/2014	HJ14-016	ADDED NOTE 1.	BS	BLB

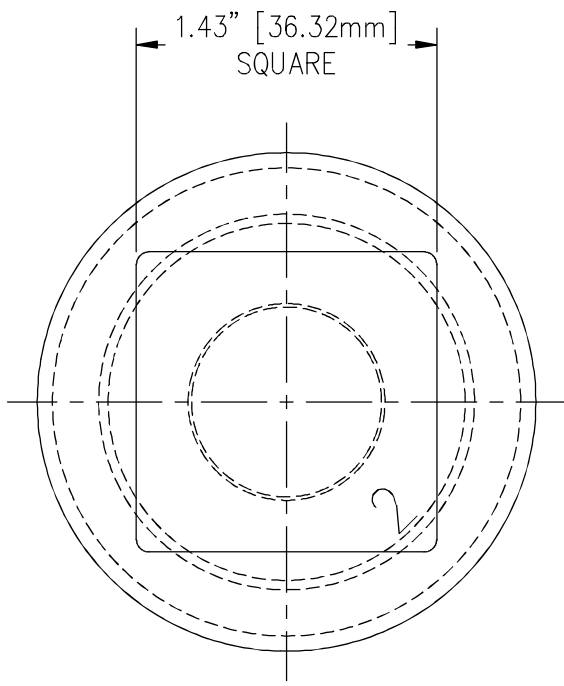

△ NOTES:  
1. PACKAGED 45 PER BOX.

TOLERANCES (EXCEPT AS NOTED)				<b>H-J ENTERPRISES, INC.</b> 3010 HIGH RIDGE BLVD. HIGH RIDGE, MO. 63049 USA PHONE 1-636-677-3421 FAX 1-636-376-1915	
DECIMAL	± .032" / .8mm			2"-11 1/2 NPT BRASS PIPE PLUG	
FRACTIONAL	±			MATERIAL CDA 36000 OR HPb59-1 OR HPb58-3 △	
ANGULAR	± 2°	CHK'D CJT	APP'D 2/4/14	DRAWING NO. PG6035-001	
DRAWN BY CJT		DATE 9-15-05		SCALE N.T.S.	