

REVISIONS					
REV.	DATE	ECN #	DESCRIPTION	BY	APPROVED
1	7/15/2010	HJ10-124	ADDED VIBRASEAL NOTE	CJT	JFS
2	6/1/2012	HJ12-098	REDREW, ADDED ALTERNATE CORE VIEW AND MADE CORE DIMENSIONS REFERENCE	CLS	JFS
3	12/26/2012	HJ12-254	ADDED HPb58-3 AS ALTERNATE MATERIAL	CLS	JFS
4	2/3/2014	HJ14-016	ADDED NOTE 4.	BS	BLB

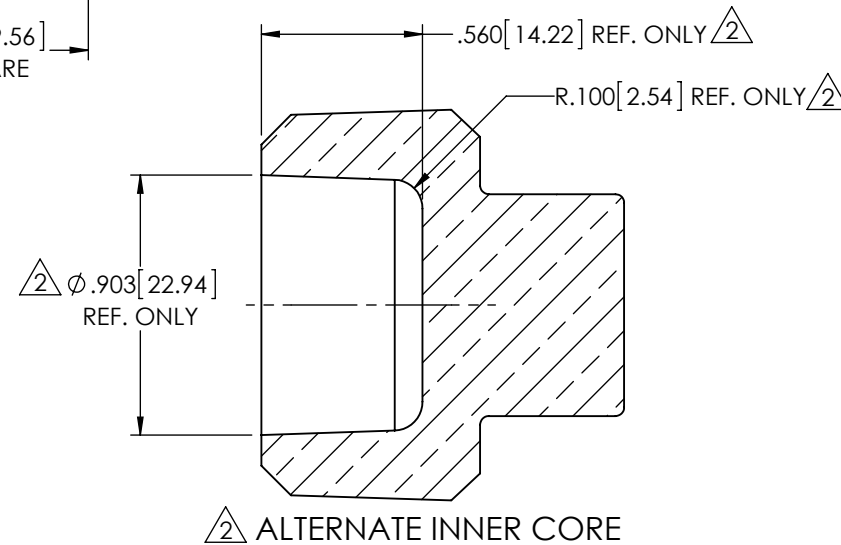
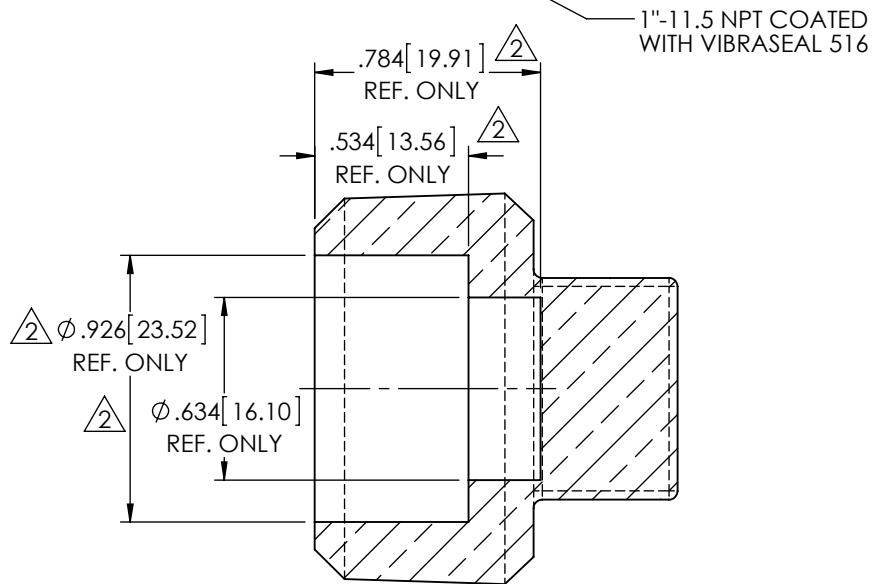
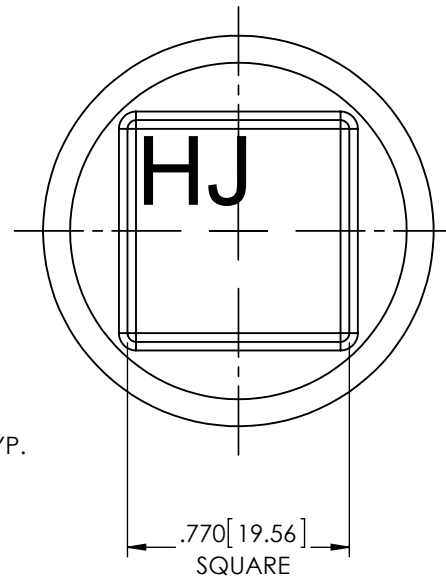
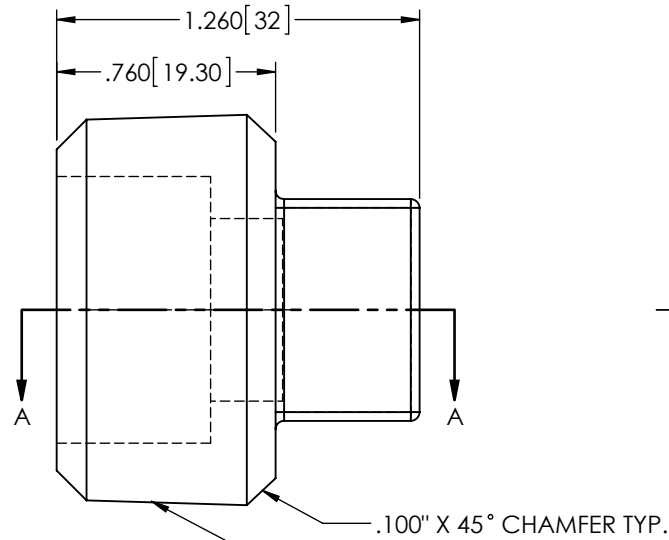

SECTION A-A

- NOTE:
1. REFER TO DV1000-002-ILL FOR VIBRASEAL APPLICATION.
 2. ALL FILLETS AND ROUNDS R.03" UNLESS OTHERWISE NOTED.
 3. EITHER INNER CORE IS ACCEPTABLE AS IT IS A NON-CRITICAL FEATURE.
 4. PACKAGED 120 PER BOX.

PROPRIETARY AND CONFIDENTIAL
 THE INFORMATION CONTAINED IN THIS DRAWING IS THE SOLE PROPERTY OF H-J ENTERPRISES, INC. ANY REPRODUCTION IN PART OR AS A WHOLE WITHOUT THE WRITTEN PERMISSION OF H-J ENTERPRISES, INC. IS PROHIBITED.

TOLERANCES (EXCEPT AS NOTED)	
DECIMAL	+/- .032"/.8mm
FRACTIONAL	+/-
ANGULAR	+/- 2 Degrees



H - J ENTERPRISES, INC.
 3010 HIGH RIDGE BLVD. HIGH RIDGE, MO. 63049 USA
 PHONE 1-636-677-3421 FAX 1-636-376-1915

1"-11.5 SQUARE HEAD CORED

MATERIAL CDA 84400 OR HPb58-3

CHK'D CJT APP'D 2/3/14
 SCALE N.T.S.

DRAWING NO. PG6031-002

DRAWN BY CJT DATE 08/28/2002