

REVISIONS					
NO.	DATE	ECN	REMARKS	BY	APPD.
1	3/31/14	HJ14-044	ADDED H62 TO MATERIAL.	BS	BLB

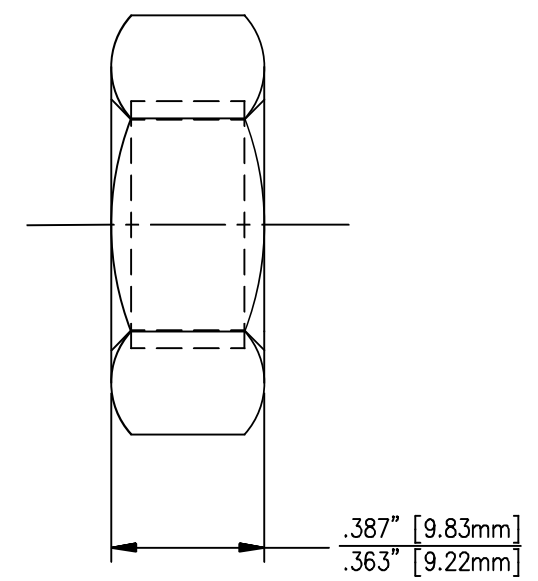
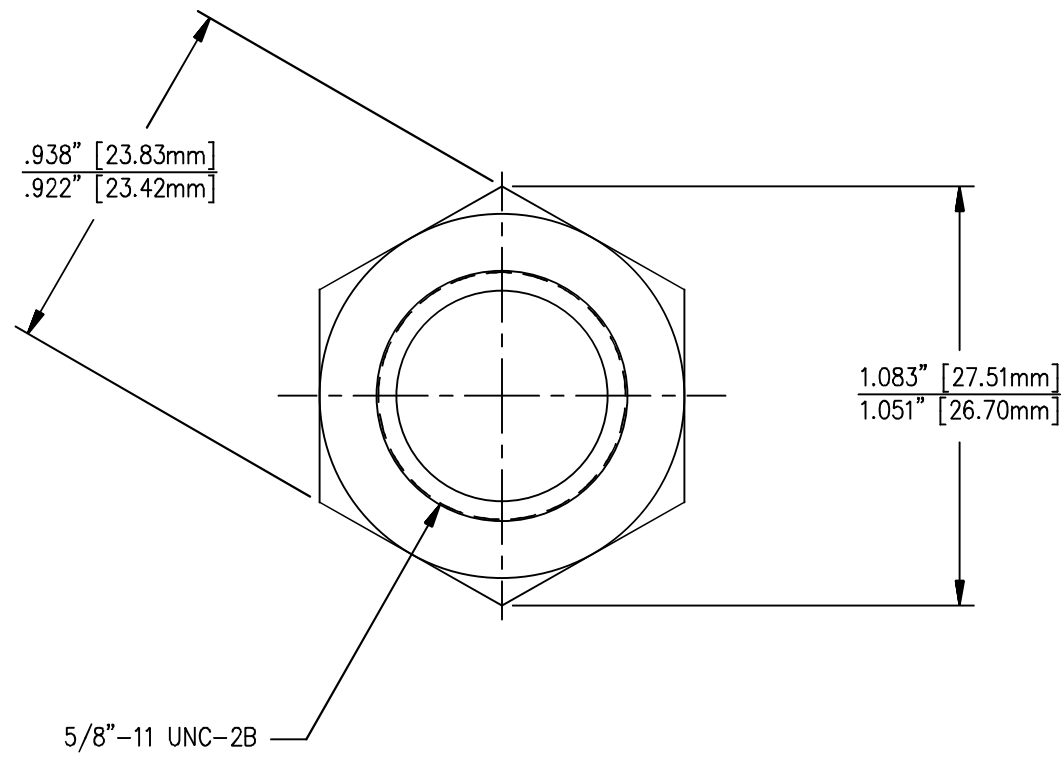

TOLERANCES (EXCEPT AS NOTED)				H-J ENTERPRISES, INC. 3010 HIGH RIDGE BLVD. HIGH RIDGE, MO. 63049 USA PHONE 1-636-677-3421 FAX 1-636-376-1915	
DECIMAL $\pm .032" / .8\text{mm}$				MATERIAL H62 OR CDA 36000 BRASS FREE CUTTING	
FRACTIONAL \pm		DRAWN BY CJT		DATE 5-18-99	
ANGULAR $\pm 2^\circ$		CHECK'D CJT		APP'D 3/31/14	
		SCALE N.T.S.		DRAWING NO. NT0013-001	