

REVISIONS					
REV.	DATE	ECN #	DESCRIPTION	BY	APPROVED

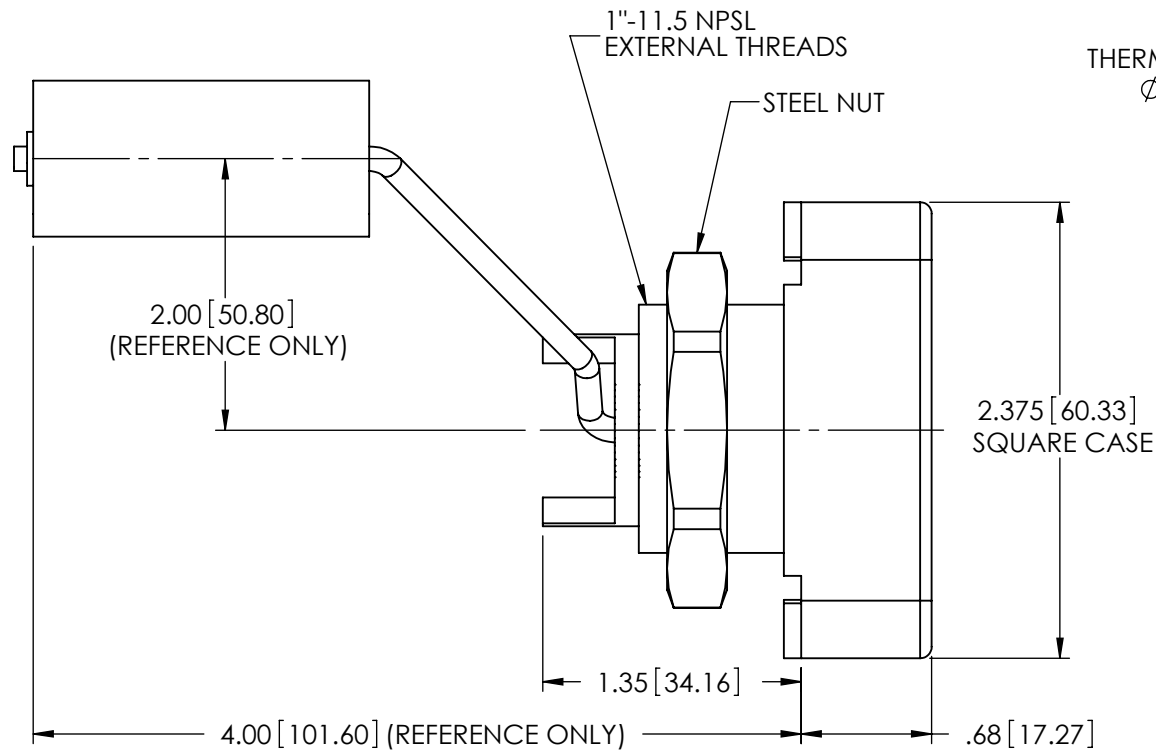

THERMOPLASTIC FLOAT
 ϕ .813" X 1.75"L

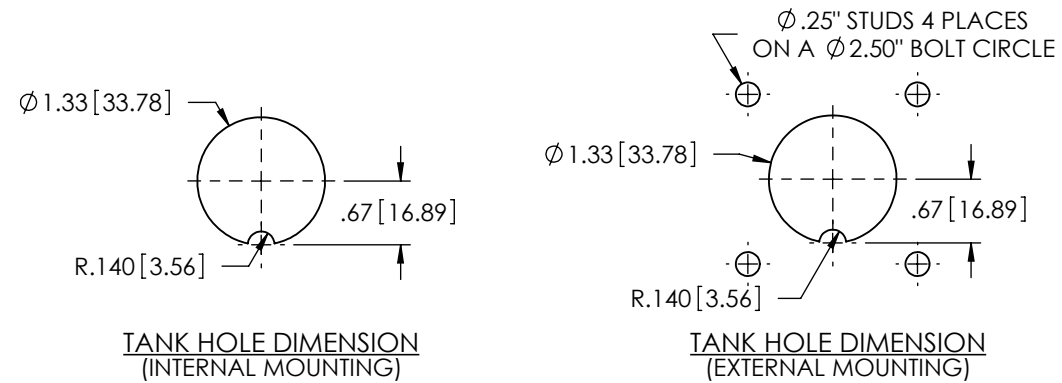
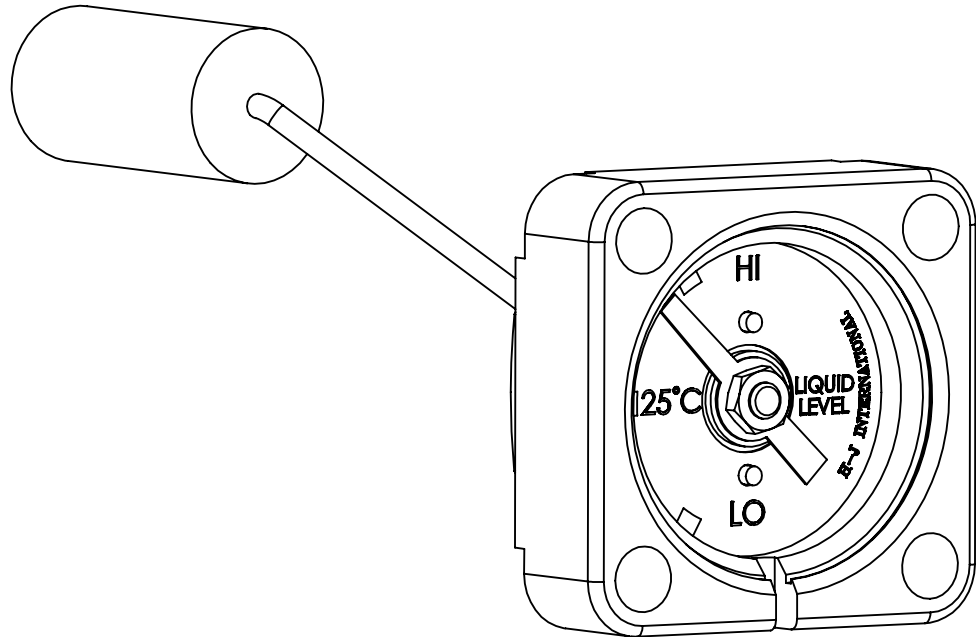
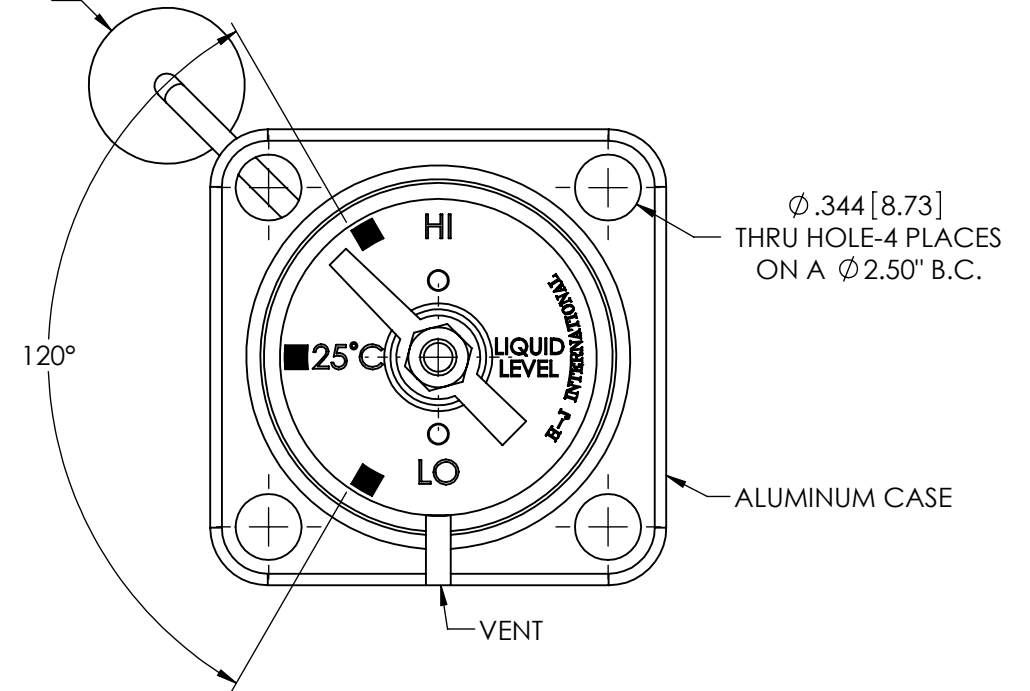

PROPRIETARY AND CONFIDENTIAL
 THE INFORMATION CONTAINED IN THIS DRAWING IS THE SOLE PROPERTY OF H-J INTERNATIONAL, INC. ANY REPRODUCTION IN PART OR AS A WHOLE WITHOUT THE WRITTEN PERMISSION OF H-J INTERNATIONAL, INC. IS PROHIBITED.

TOLERANCES (EXCEPT AS NOTED)	
DECIMAL	+/- .032"/.8mm
FRACTIONAL	+/-
ANGULAR	+/- 2 Degrees



H - J INTERNATIONAL, INC.
 3010 HIGH RIDGE BLVD. HIGH RIDGE, MO. 63049 USA
 PHONE 1-636-677-3421 FAX 1-636-376-1915

**LIQUID LEVEL GAUGE ASSEMBLY
 NO TANK GASKET**

MATERIAL SEE DRAWING

CHK'D CJT APP'D 4/22/14
 SCALE N.T.S.

DRAWING NO.
INT005-008

DRAWN BY BS DATE 4/22/2014