

REVISIONS					
REV.	DATE	ECN #	DESCRIPTION	BY	APPROVED
2	11/18/2009		REDRAWN.	CJT	JFS

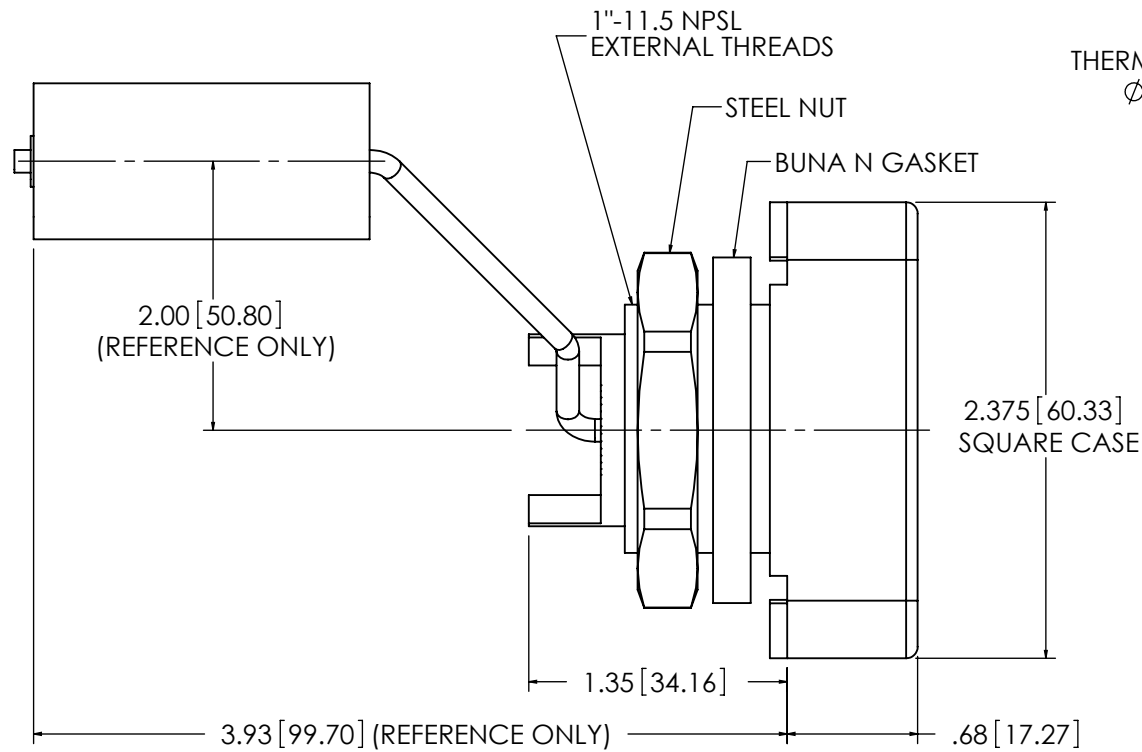

THERMOPLASTIC FLOAT
 ϕ .813" X 1.75"L

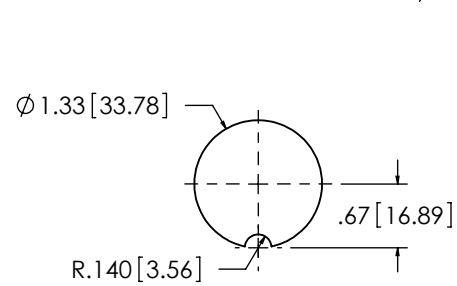
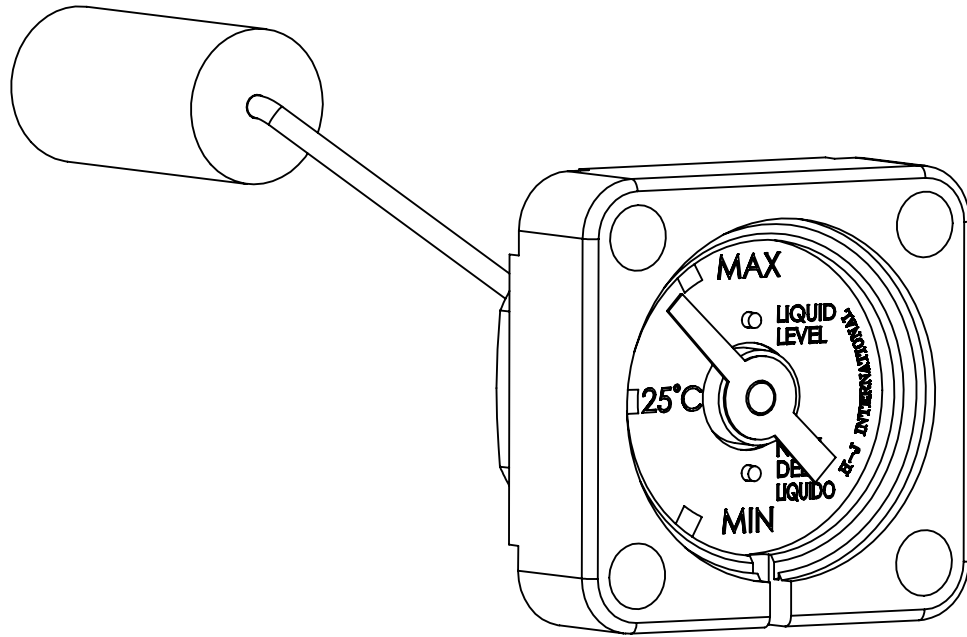
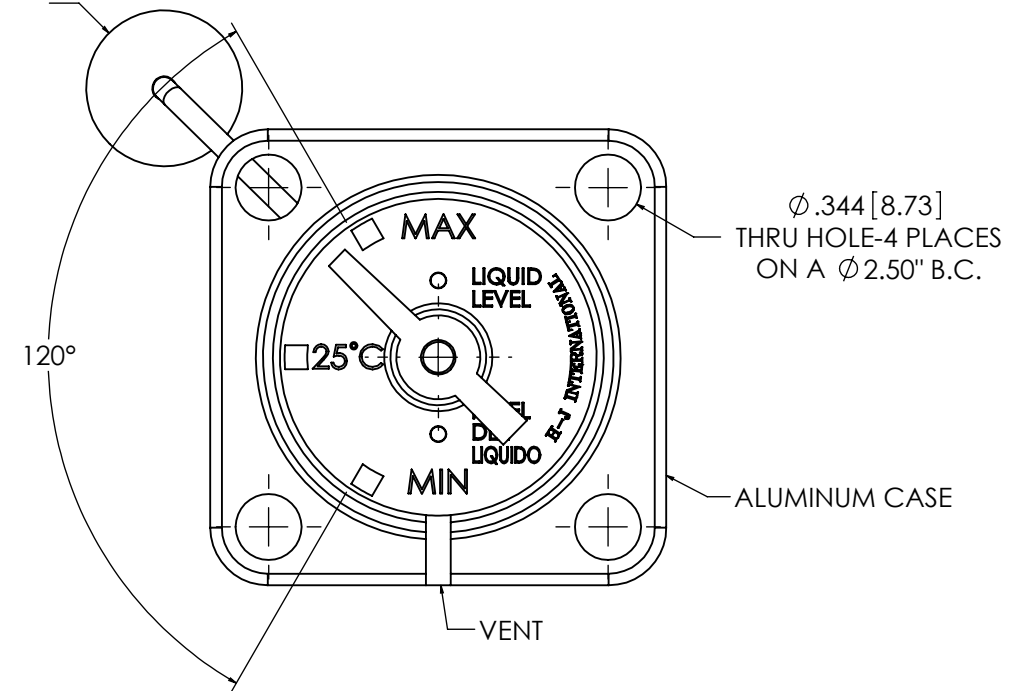

TANK HOLE DIMENSION
 (INTERNAL MOUNTING)

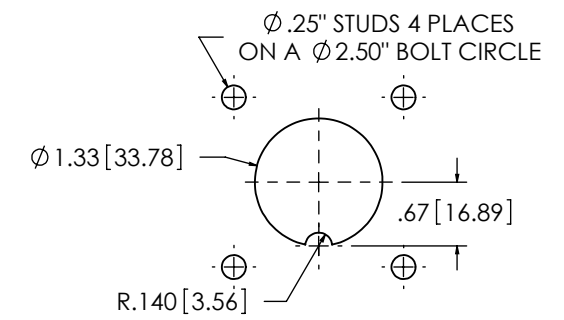

TANK HOLE DIMENSION
 (EXTERNAL MOUNTING)

PROPRIETARY AND CONFIDENTIAL
 THE INFORMATION CONTAINED IN THIS DRAWING IS THE SOLE PROPERTY OF H-J INTERNATIONAL, INC. ANY REPRODUCTION IN PART OR AS A WHOLE WITHOUT THE WRITTEN PERMISSION OF H-J INTERNATIONAL, INC. IS PROHIBITED.

TOLERANCES (EXCEPT AS NOTED)	
DECIMAL	+/- .032"/.8mm
FRACTIONAL	+/-
ANGULAR	+/- 2 Degrees



H - J INTERNATIONAL, INC.
 3010 HIGH RIDGE BLVD. HIGH RIDGE, MO. 63049 USA
 PHONE 1-636-677-3421 FAX 1-636-376-1915

LIQUID LEVEL GAUGE ASSEMBLY - SPANISH			
MATERIAL		SEE DRAWING	
CHK'D	APP'D	DRAWING NO.	
		INT005-004	
DRAWN BY	PWD	DATE	8-7-03
		SCALE	N.T.S.