

1/2-13 UNC X 1.00DP
BRASS MOUNTING INSERT

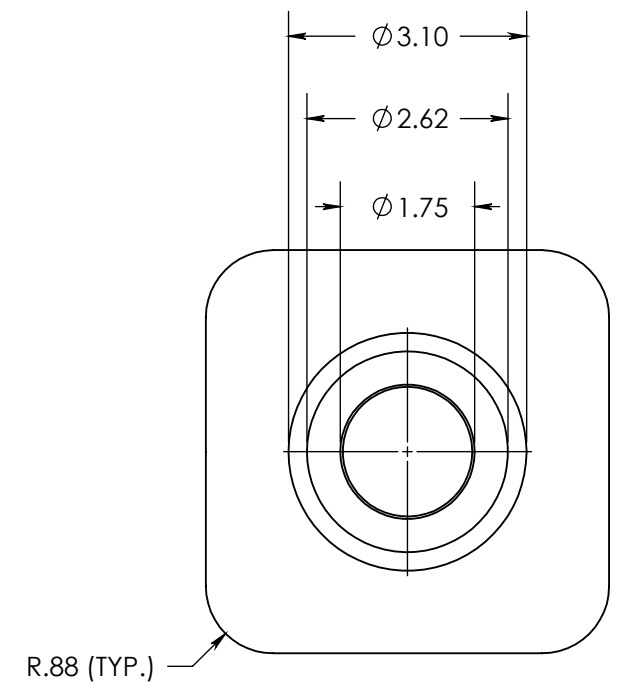
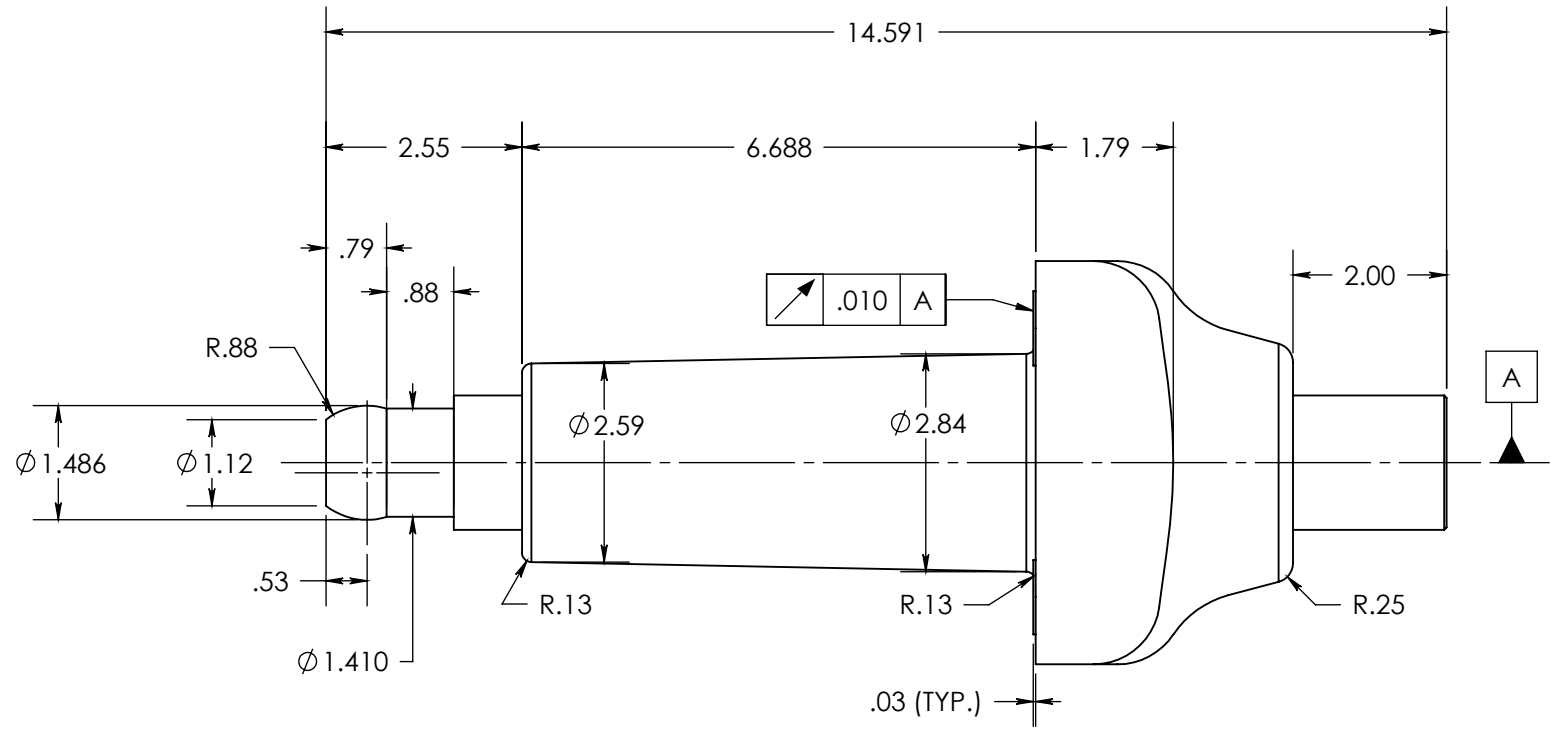

- NOTES:
1. ALL CONTACT SURFACES TO BE CLEAN & FREE FROM FLASH
- MATERIAL:
1. E09 - CYCLOALIPHATIC EPOXY
2. E06 - BISPHENOL-A EPOXY
3. HD ETP COPPER, C11000; FINISH SILVER PLATED .0005 MIN. THICKNESS
- SPECIFICATIONS:
1. RATED VOLTAGE 5kV
2. POWER FREQUENCY WITHSTAND 19kV
3. BASIC IMPULSE LEVEL 60KV
4. NOMINAL CURRENT RATING 1200 AMPS
5. LEAKAGE DISTANCE 4.25"
6. TEMPERATURE CLASSIFICATION..... -50°C TO +105°C
7. FINISHED WEIGHT 16.5 LBS.

PROPRIETARY AND CONFIDENTIAL
THE INFORMATION CONTAINED IN THIS DRAWING IS THE SOLE PROPERTY OF H-J INTERNATIONAL, INC. ANY REPRODUCTION IN PART OR AS A WHOLE WITHOUT THE WRITTEN PERMISSION OF H-J INTERNATIONAL, INC. IS STRICTLY PROHIBITED.

BREAK ALL SHARPS UNLESS OTHERWISE NOTED

TOLERANCES (EXCEPT AS NOTED)

ONE PLACE MM ±1.50
TWO PLACE MM ±0.75
TWO PLACE DEC. ±.060
THREE PLACE DEC. ±.030
FRACTIONS ± 1/16"
ANGLES 2°

	APPROVED BY	DB	DATE	2-14-03
	CHECKED BY	RM	DATE	2-14-03
	DRAWN BY	DB	DATE	2-14-03
	TOOL NO.	T15-015-0		
PRODUCT GRP.	1500 SERIES			

H-J INTERNATIONAL, INC.
3010 HIGH RIDGE BLVD, HIGH RIDGE, MO. 63049 USA
PHONE 1-636-677-3421 FAX 1-636-376-1915

**5KV, 1200A
SWITCHGEAR BUSHING**

DRAWING NO. **15-015-004**

SCALE **1:2.5** SIZE B REV. SHEET 1 OF 1