

REVISIONS					
REV.	DATE	ECN#	DESCRIPTION	BY	APPROVED

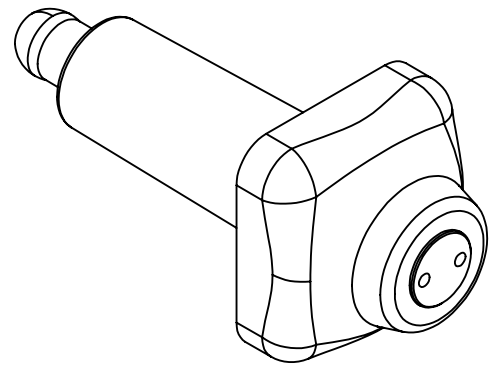
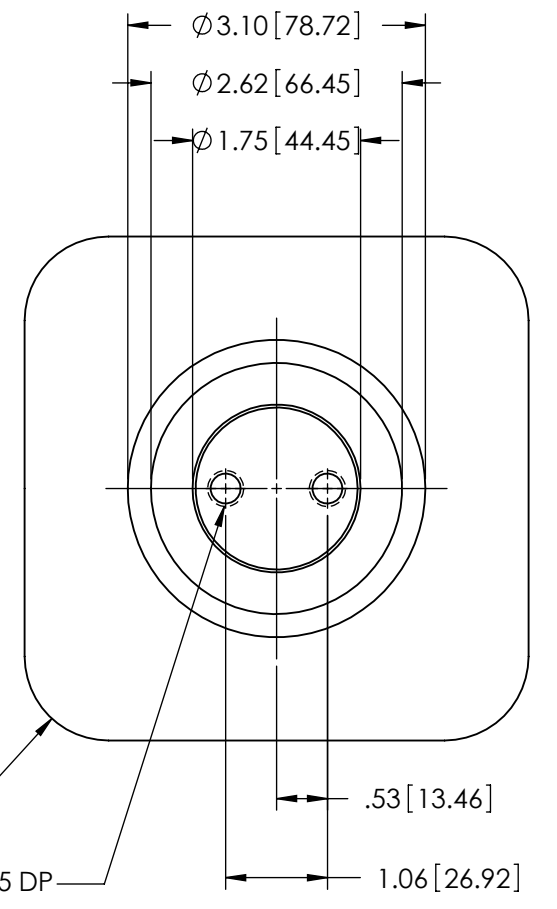
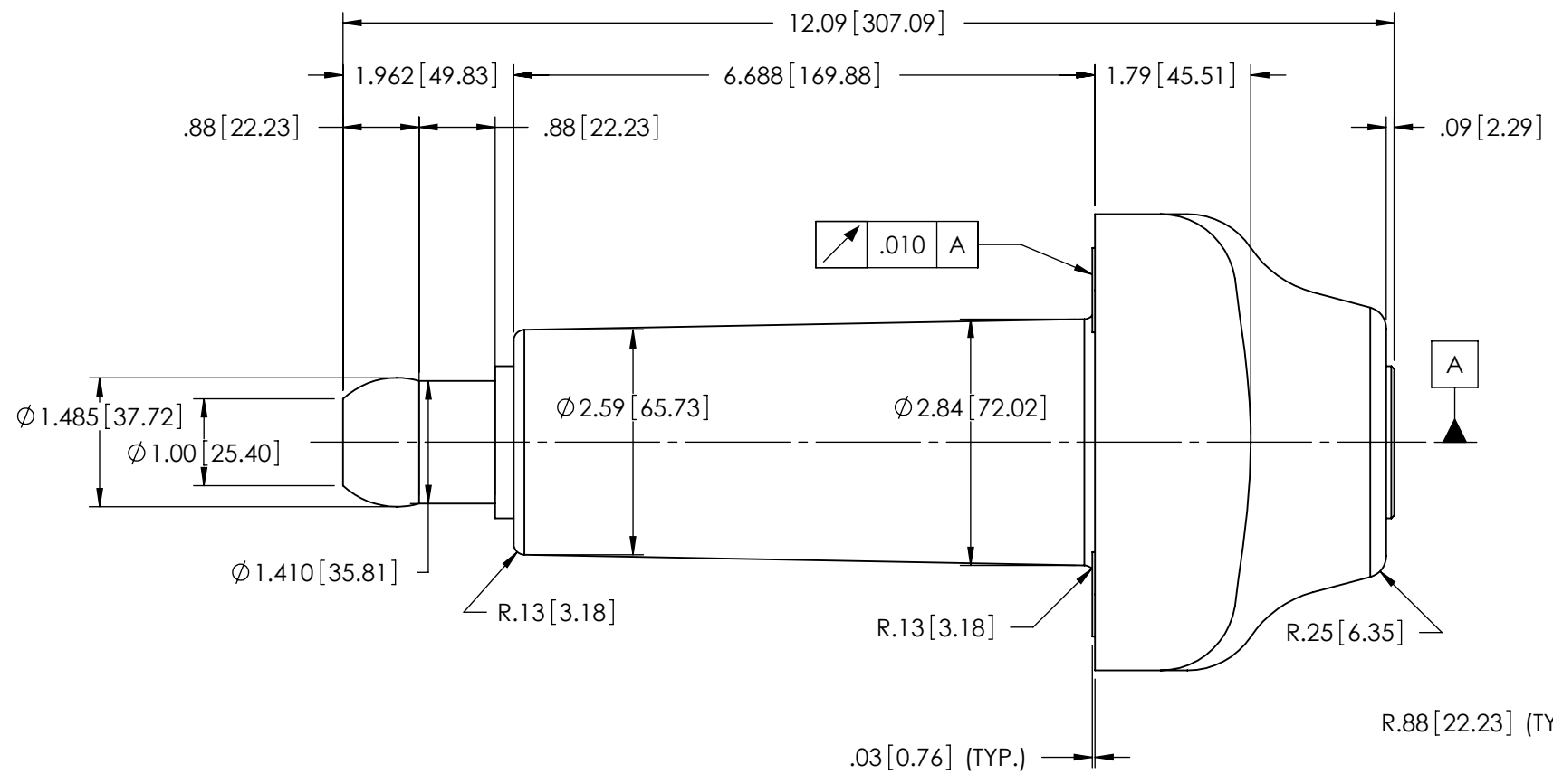
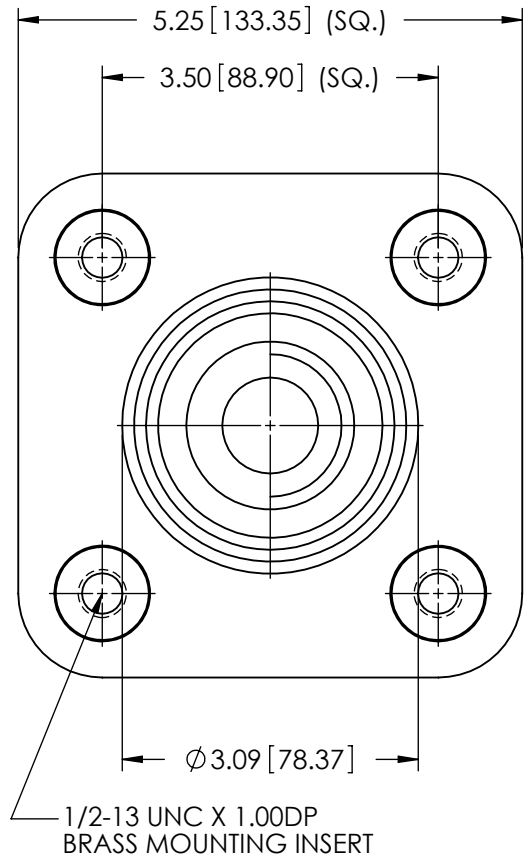

NOTES:
1. ALL CONTACT SURFACES TO BE CLEAN & FREE FROM FLASH

MATERIAL:
1. E04 - CYCLOALIPHATIC EPOXY (OUTDOOR)
2. E06 - BISPHENOL-A EPOXY (INDOOR)
3. HD ETP COPPER, C11000; FINISH SILVER PLATED .0005 MIN. THICKNESS

SPECIFICATIONS:
1. RATED VOLTAGE 5kV
2. POWER FREQUENCY WITHSTAND 19kV
3. BASIC IMPULSE LEVEL 60KV
4. NOMINAL CURRENT RATING 1200 AMPS
5. LEAKAGE DISTANCE 4.25"
6. TEMPERATURE CLASSIFICATION..... -50°C TO +105°C
7. FINISHED WEIGHT 14.25 LBS.

PROPRIETARY AND CONFIDENTIAL
THE INFORMATION CONTAINED IN THIS DRAWING IS THE SOLE PROPERTY OF H-J INTERNATIONAL, INC. ANY REPRODUCTION IN PART OR AS A WHOLE WITHOUT THE WRITTEN PERMISSION OF H-J INTERNATIONAL, INC. IS STRICTLY PROHIBITED.

BREAK ALL SHARPS UNLESS OTHERWISE NOTED

TOLERANCES (EXCEPT AS NOTED)

ONE PLACE MM	±1.50
TWO PLACE MM	±0.75
TWO PLACE DEC.	±.060
THREE PLACE DEC.	±.030
FRACTIONS	± 1/16"
ANGLES	2°



APPROVED BY	DB	DATE	7/17/2001
CHECKED BY	RM	DATE	7/17/2001
DRAWN BY	DB	DATE	7/17/2001
TOOL NO.	T15-015		
PRODUCT GRP.	1500 SERIES		

H-J INTERNATIONAL, INC.
3010 HIGH RIDGE BLVD, HIGH RIDGE, MO. 63049 USA
PHONE 1-636-677-3421 FAX 1-636-376-1915

5kV, 1200A
SWITCHGEAR BUSHING

MATERIAL	QTY.
DRAWING NO.	15-015-000
SCALE	1:2
SIZE	B
REV.	
SHEET	1 OF 1