

| REV |  | DATE | ECN # | REVISIONS | DESCRIPTION | BY | APPROVED |
|-----|--|------|-------|-----------|-------------|----|----------|
|     |  |      |       |           |             |    |          |

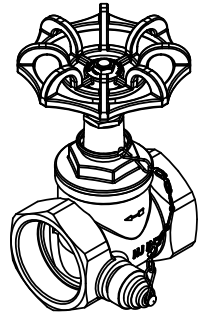

SAMPLING DEVICE 3/8"  
W/ 5/8" HEX NUT

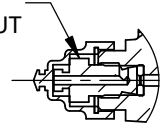

SECTION B-B

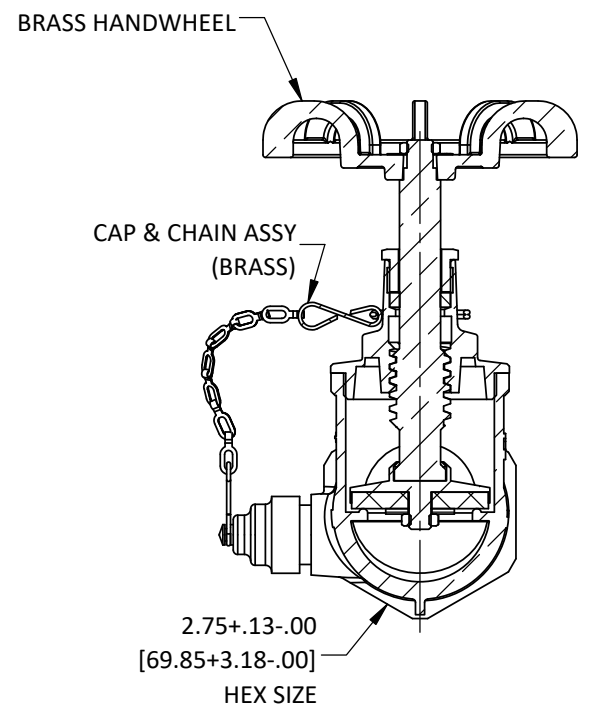
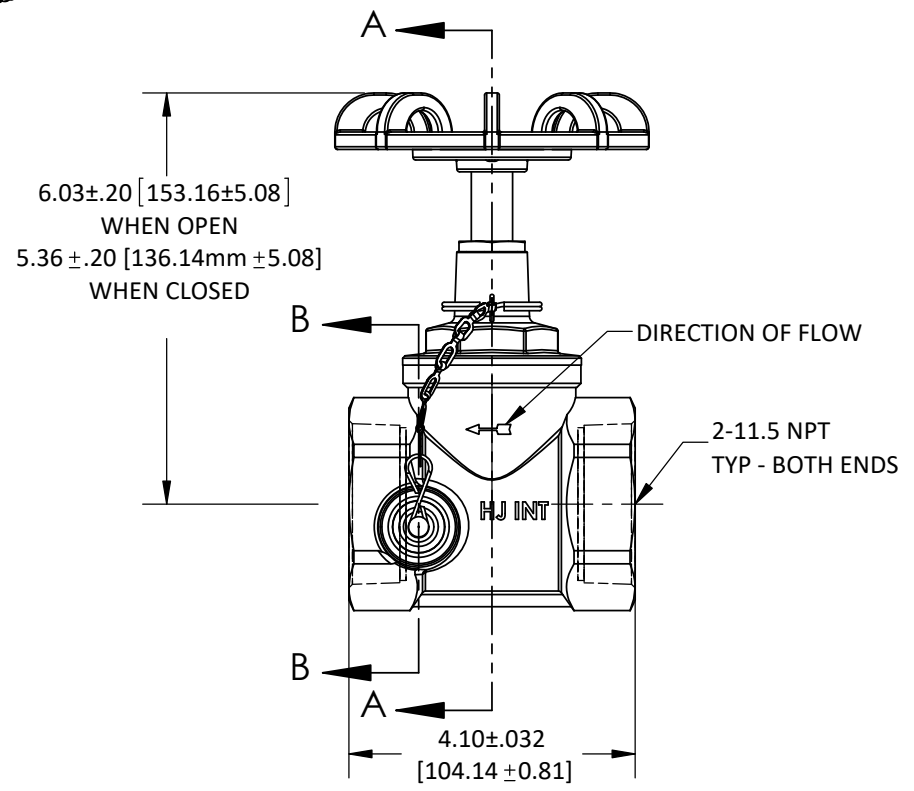

SECTION A-A

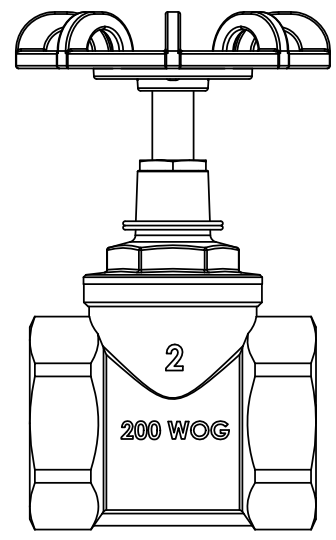

- NOTES:
1. ELECTRICAL APPARATUS VALVE.
  2. RATING: 200 LBS. WOG (WATER-OIL-GAS)
  3. VALVE BODY: C377 or HPb58-3
  4. DISC - PTFE
  5. GAKSETS: VITON
  6. SAMPLER IS ON OUTLET SIDE OF VALVE

|   |   |              |  |   |
|---|---|--------------|--|---|
|   | <b>TOLERANCES</b><br>(EXCEPT AS NOTED)          |              | <b>THE H-J FAMILY OF COMPANIES</b><br>3010 HIGH RIDGE BLVD. HIGH RIDGE, MO. 63049 USA<br>PHONE 1-636-677-3421 FAX 1-636-677-7808 |   |
|   | DECIMAL<br>±<br>FRACTIONAL<br>±<br>ANGULAR<br>± |              | <b>2" GLOBE VALVE W/ SIDE SAMPLER</b>  |   |
| <b>PROPRIETARY AND CONFIDENTIAL</b><br>THE INFORMATION CONTAINED IN THIS DRAWING IS THE SOLE PROPERTY OF THE H-J FAMILY OF COMPANIES. ANY REPRODUCTION IN PART OR AS A WHOLE WITHOUT THE WRITTEN PERMISSION OF THE H-J FAMILY OF COMPANIES IS PROHIBITED. |   | DRAWN BY CJT | DATE 12-21-04  | MATERIAL SEE DRAWING<br>CHK'D - APP'D -<br>SCALE N.T.S. |
|   |   |              | DRAWING NO. DV1013-001   |   |