

REVISIONS					
REV	DATE	ECN #	DESCRIPTION	BY	APPROVED

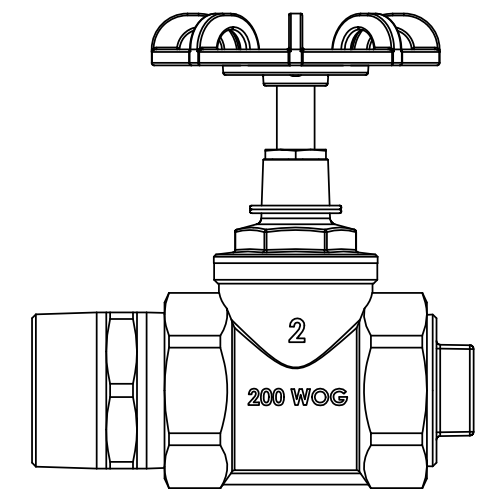
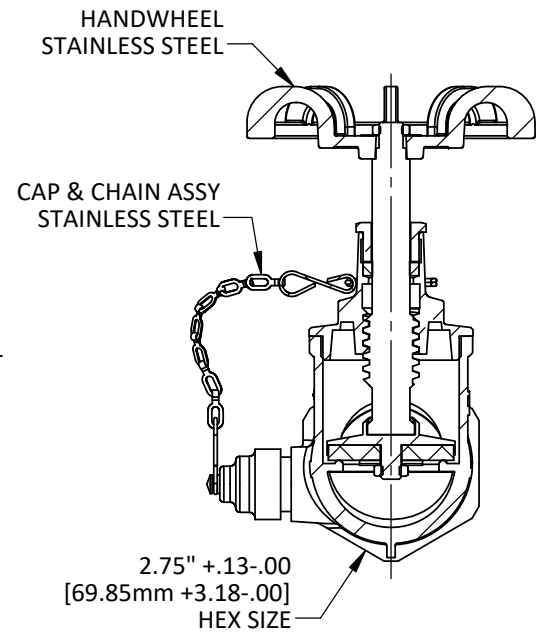
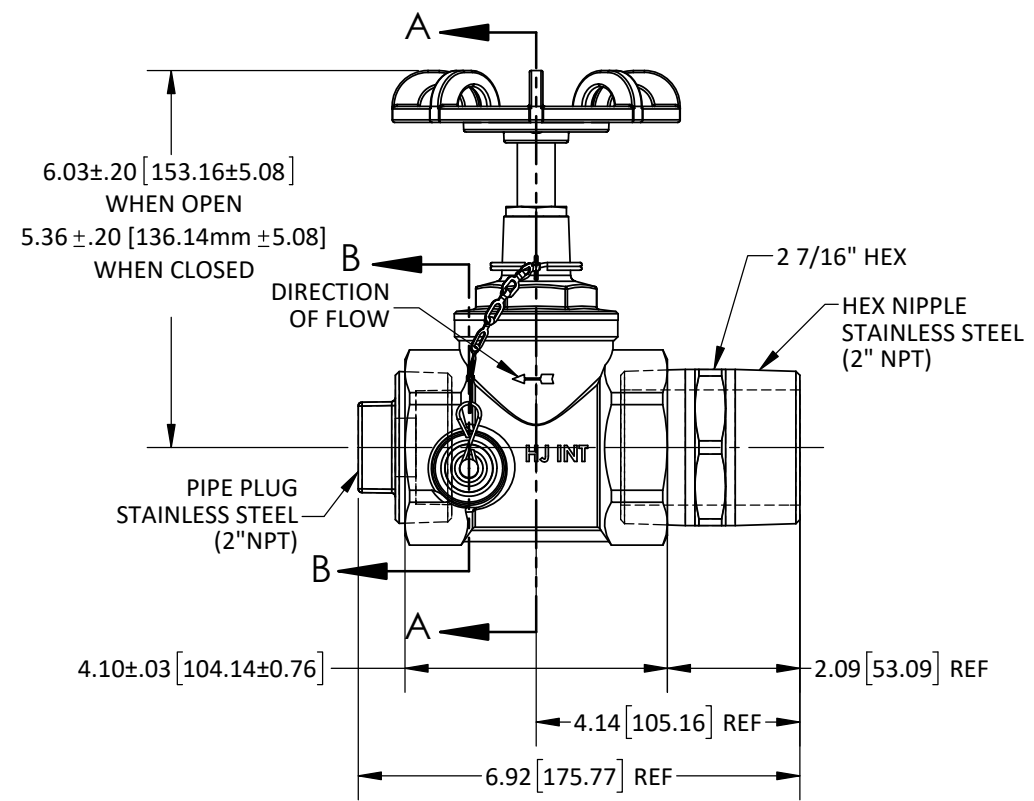
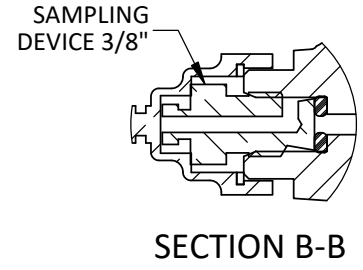
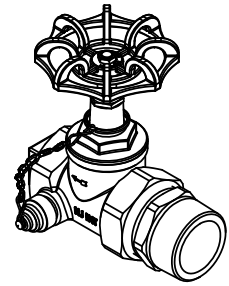

- NOTES:
1. ELECTRICAL APPARATUS VALVE.
  2. RATING: 200 LBS. WOG (WATER-OIL-GAS)
  3. VALVE BODY: 316 STAINLESS STEEL
  4. PTFE DISC
  5. GASKETS: VITON
  6. SAMPLER IS ON OUTLET SIDE OF VALVE.

	<b>TOLERANCES</b> (EXCEPT AS NOTED)		<b>THE H-J FAMILY OF COMPANIES</b> 3010 HIGH RIDGE BLVD. HIGH RIDGE, MO. 63049 USA PHONE 1-636-677-3421 FAX 1-636-677-7808		
	DECIMAL ± FRACTIONAL ± ANGULAR ±		<b>2" STAINLESS STEEL GLOBE VALVE W/ SIDE SAMPLER, STEEL PLUG &amp; NIPPLE</b>		
<b>PROPRIETARY AND CONFIDENTIAL</b> THE INFORMATION CONTAINED IN THIS DRAWING IS THE SOLE PROPERTY OF THE H-J FAMILY OF COMPANIES. ANY REPRODUCTION IN PART OR AS A WHOLE WITHOUT THE WRITTEN PERMISSION OF THE H-J FAMILY OF COMPANIES IS PROHIBITED.		MATERIAL SEE DRAWING	CHK'D - APP'D - SCALE N.T.S.	DRAWING NO. <b>DV1013-006</b>	DRAWN BY CJT DATE 9/15/05