

REVISIONS					
REV.	DATE	ECN #	DESCRIPTION	BY	APPROVED

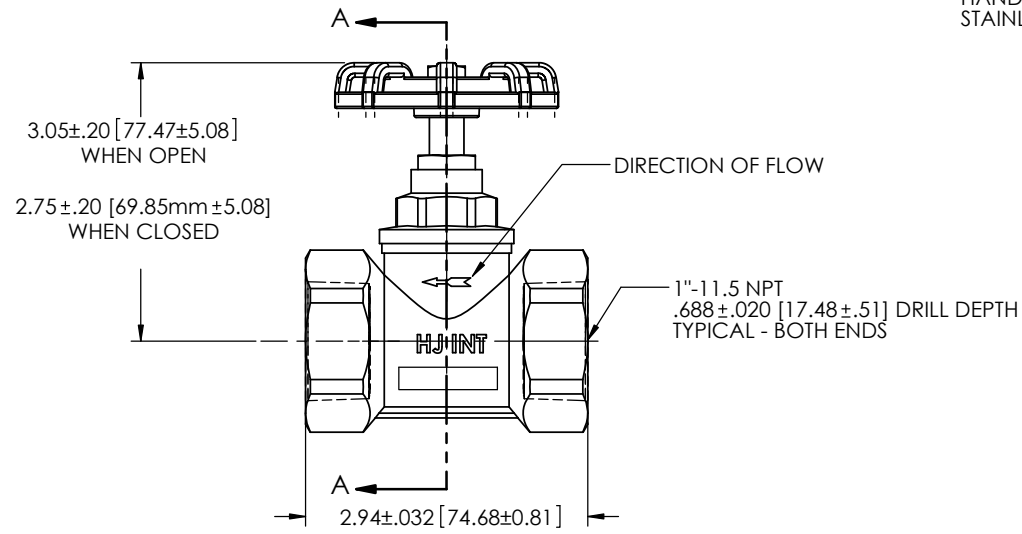

HANDWHEEL
STAINLESS STEEL

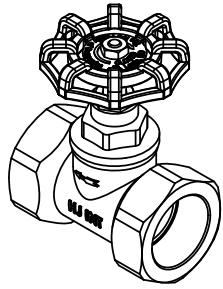
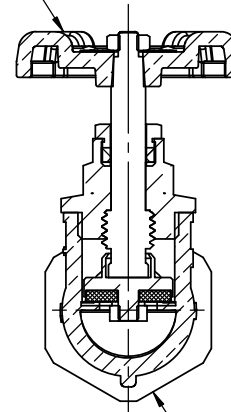

1.688 +.13 -.00 [42.86 +3.18 -.00]
HEX SIZE

SECTION A-A

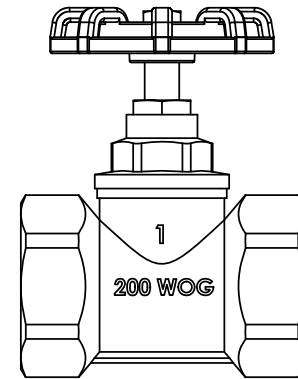

NOTES:

1. ELECTRICAL APPARATUS VALVE.
2. RATING: 200 LBS. WOG (WATER-OIL-GAS)
3. VALVE BODY: 316 STAINLESS STEEL
4. TEFLON DISC
5. GASKETS: VITON

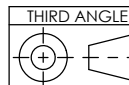

THIRD ANGLE
TOLERANCES
(EXCEPT AS NOTED)

DECIMAL

±
FRACTIONAL

±
ANGULAR

±

PROPRIETARY AND CONFIDENTIAL

THE INFORMATION CONTAINED IN THIS DRAWING IS THE SOLE PROPERTY OF THE H-J FAMILY OF COMPANIES. ANY REPRODUCTION IN PART OR AS A WHOLE WITHOUT THE WRITTEN PERMISSION OF THE H-J FAMILY OF COMPANIES IS PROHIBITED.



THE H-J FAMILY OF COMPANIES
3010 HIGH RIDGE BLVD. HIGH RIDGE, MO. 63049 USA
PHONE 1-636-677-3421 FAX 1-636-677-7808

1" STAINLESS STEEL GLOBE VALVE

MATERIAL SEE DRAWING

CHK'D - APP'D -
SCALE N.T.S.

DRAWING NO.
DV1004-006

DRAWN BY CMH

DATE 2-17-11