

REVISIONS					
REV.	DATE	ECN #	DESCRIPTION	BY	APPD

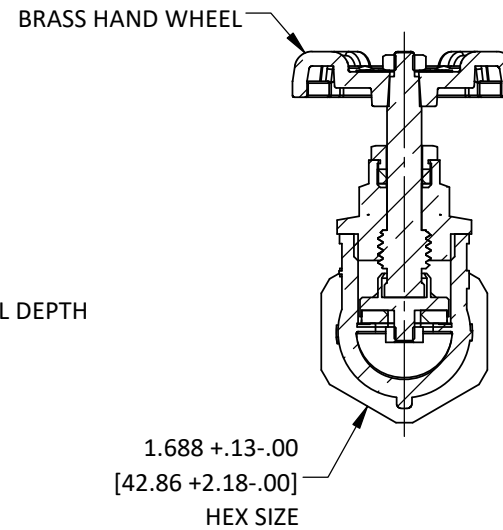

SECTION A-A

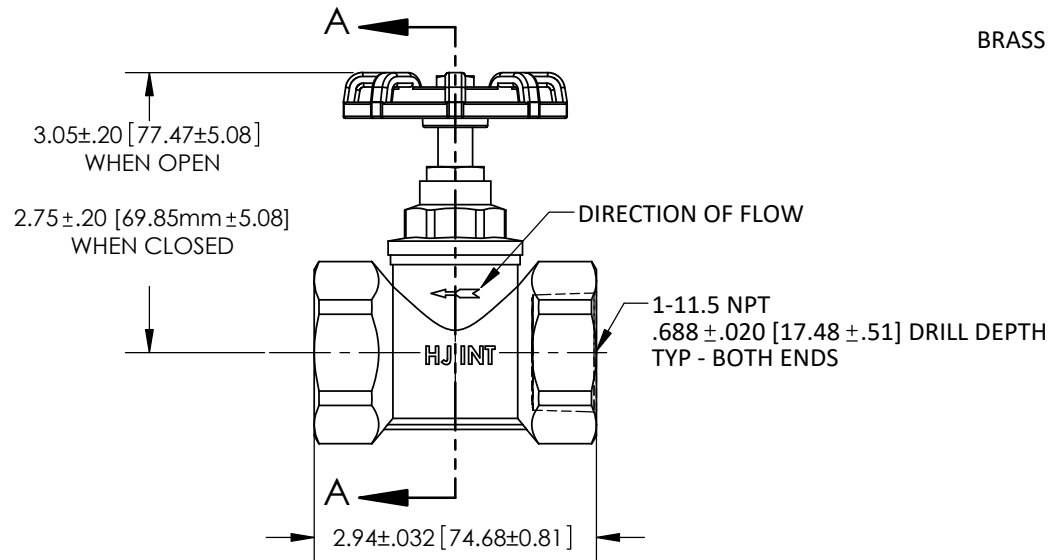
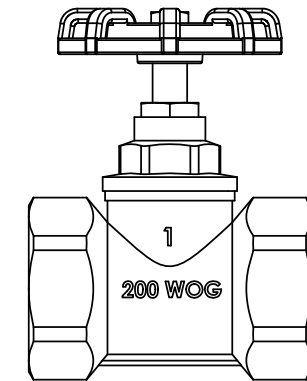

- NOTES:
1. ELECTRICAL APPARATUS VALVE.
  2. RATING: 200 LBS. WOG (WATER-OIL-GAS)
  3. VALVE BODY: C377 or HPb58-3
  4. DISC - TEFLON-PTFE
  5. GASKETS: VITON

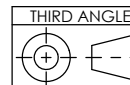

THIRD ANGLE  
TOLERANCES  
(EXCEPT AS NOTED)

DECIMAL	±
FRACTIONAL	±
ANGULAR	±
	±

**PROPRIETARY AND CONFIDENTIAL**

THE INFORMATION CONTAINED IN THIS DRAWING IS THE SOLE PROPERTY OF THE H-J FAMILY OF COMPANIES. ANY REPRODUCTION IN PART OR AS A WHOLE WITHOUT THE WRITTEN PERMISSION OF THE H-J FAMILY OF COMPANIES IS PROHIBITED.



THE H-J FAMILY OF COMPANIES  
 3010 HIGH RIDGE BLVD. HIGH RIDGE, MO. 63049 USA  
 PHONE 1-636-677-3421 FAX 1-636-677-7808

1" GLOBE VALVE

MATERIAL SEE DRAWING

CHK'D	-	APP'D	-	DRAWING NO.	DV1004-001
SCALE	N.T.S.				

DRAWN BY CJT DATE 5-3-04