

REVISIONS					
REV.	DATE	ECN #	DESCRIPTION	BY	APPROVED
1	10/18/2012	PQI8429	REMOVED +/- .032" GENERAL TOLANCE, ADDED +0"-.01" TOLERANCE, MAX DIAMETER INCREASED FROM .4892".	CJT	PM
2	4/1/2013	HJ13-081	REMOVED +.000-.01" TOLERANCE, ADDED .020" TO THE TOLERANCE BLOCK.	BS	ABB
3	4/9/2013	PQI# 9474	REDIMENSIONED.	BS	PM

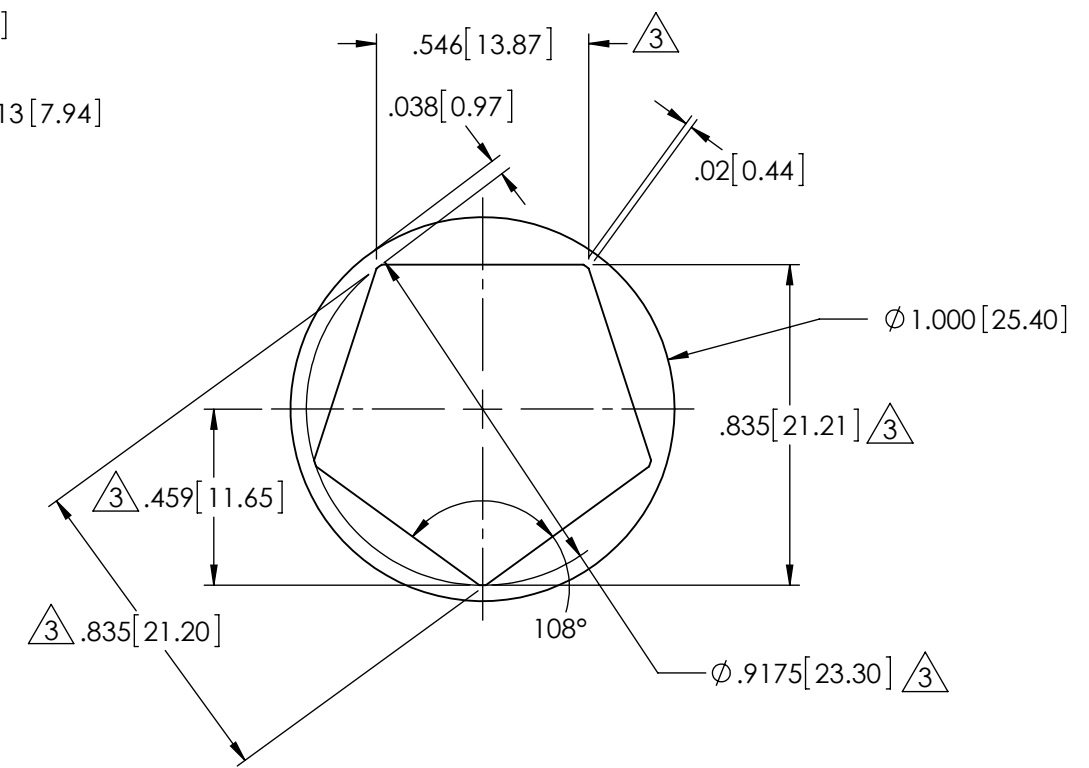
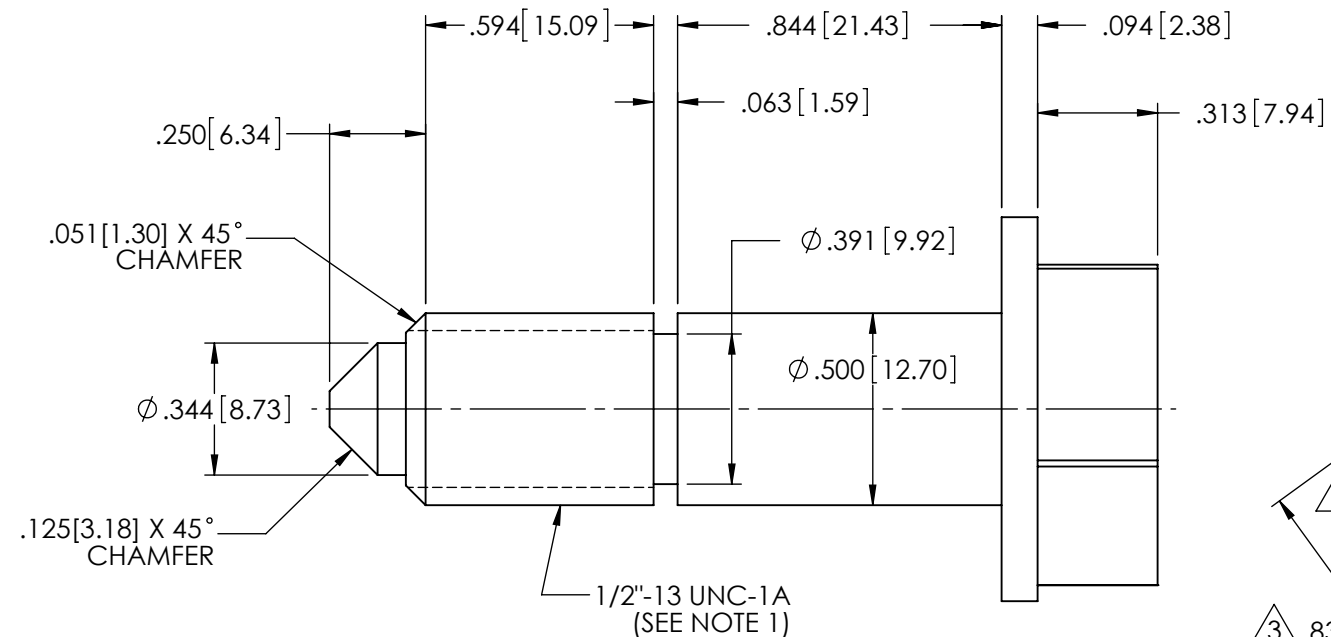

NOTES:
 1. CLASS 1A: ACCEPTABILITY CRITERIA PER ANSI/ASME B1.3M-1986. KEEP MINIMUM MAJOR DIAMETER AS CLOSE AS POSSIBLE TO Ø .4822 [12.25] FOR AN EASIER INSTALLATION OF THE BOLT. MAXIMUM MAJOR DIAMETER OF THE BOLT SHOULD NOT EXCEED Ø .4932 [12.53].

PROPRIETARY AND CONFIDENTIAL
 THE INFORMATION CONTAINED IN THIS DRAWING IS THE SOLE PROPERTY OF H-J INTERNATIONAL, INC. ANY REPRODUCTION IN PART OR AS A WHOLE WITHOUT THE WRITTEN PERMISSION OF H-J INTERNATIONAL, INC. IS PROHIBITED.

TOLERANCES (EXCEPT AS NOTED)	
DECIMAL	$\triangle 2$
+/- .020" / .5mm	
FRACTIONAL	
+/-	
ANGULAR	
+/- 2 Degrees	



H - J INTERNATIONAL, INC.
 3010 HIGH RIDGE BLVD. HIGH RIDGE, MO. 63049 USA
 PHONE 1-636-677-3421 FAX 1-636-376-1915

PENTAHEAD BOLT

MATERIAL		STAINLESS STEEL, GRADE 303	
CHK'D	CJT	APP'D	4/1/13
DRAWN BY		DATE	DRAWING NO.
CJT		4/19/2012	B00067-001
SCALE		N.T.S.	