

REVISIONS

REV.	DATE	ECN #	DESCRIPTION	BY	APP'D
1	2/17/03	HJ03-011	REDREW CAP	CJT	SP
2	5/5/09	HJ09-097	ADDED "STAINLESS STEEL"	SMM	JFS
3	2/27/2015	HJ14-137	SOLIDWORKS REDRAW. ADDED TIN PLATING. REMOVED HEX CUTOUT. ADDED MAT'L NOTE. CHG'D HEX NUT QTY, WAS 6-TO-4. CHG'D BOLT LGTHS, WAS 1.95-TO-1.75, WAS 2.46-TO-2.25	TJF	BLB

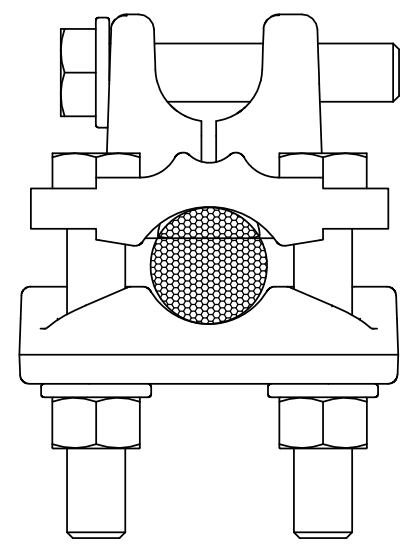

LARGE GROOVE  
(800 MCM)

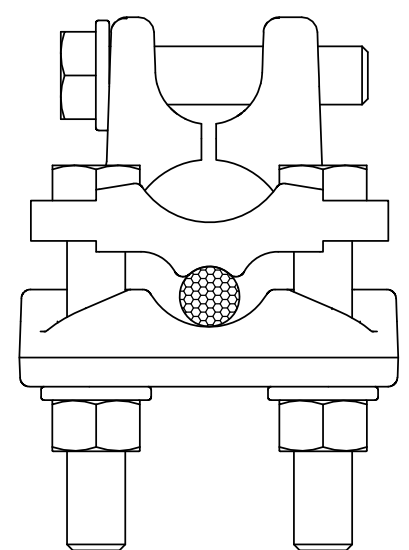

SMALL GROOVE  
(#6 SOL.)

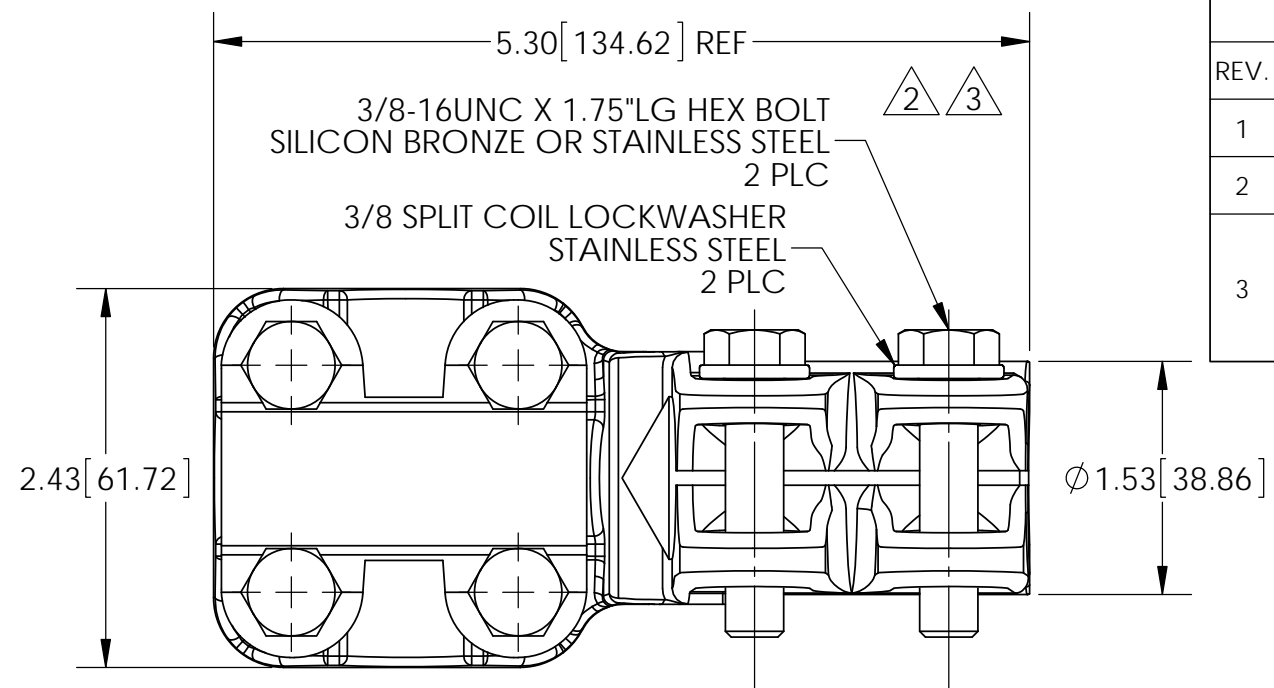

3/8-16UNC X 1.75"LG HEX BOLT  
SILICON BRONZE OR STAINLESS STEEL  
2 PLC

3/8 SPLIT COIL LOCKWASHER  
STAINLESS STEEL  
2 PLC

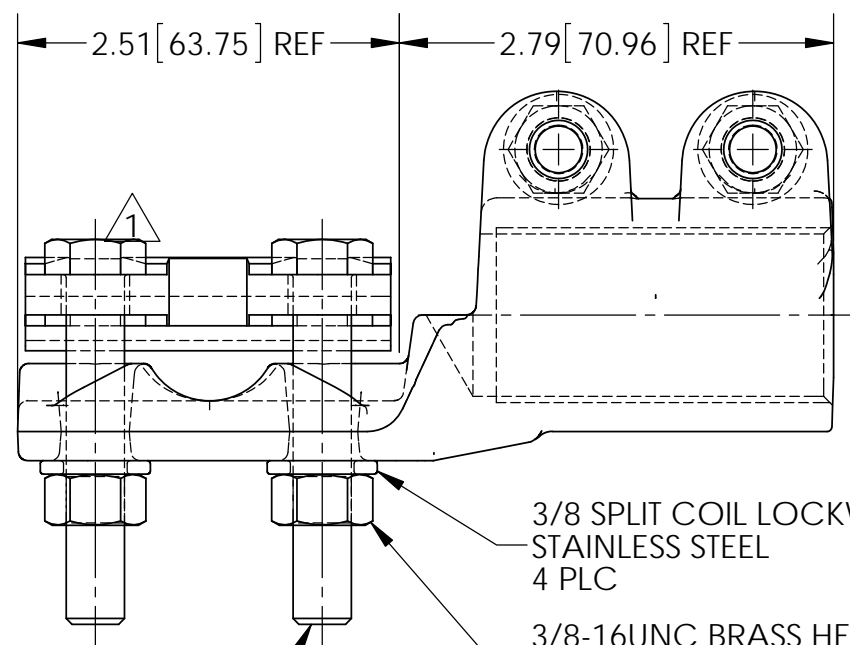

3/8-16UNC X 2.25"LG HEX BOLT  
SILICON BRONZE OR STAINLESS STEEL  
4 PLC

3/8 SPLIT COIL LOCKWASHER  
STAINLESS STEEL  
4 PLC

3/8-16UNC BRASS HEX NUT  
TIN-PLATED  
4 PLC

1 1/8-12UNF-2B  
2.170"MIN TAP DEPTH

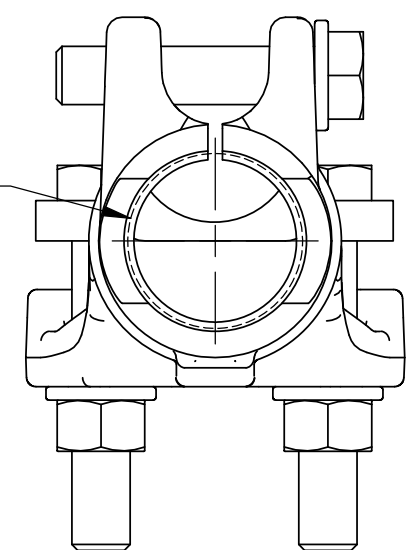
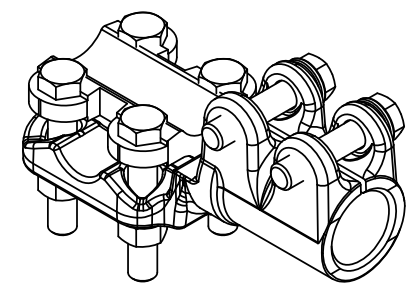

MATERIAL:

- 1. AERIAL LUG - CDA 84400 - TIN PLATED
- 2. AERIAL CAP - CDA 95500 - TIN PLATED

**PROPRIETARY AND CONFIDENTIAL**  
THE INFORMATION CONTAINED IN THIS DRAWING IS THE SOLE PROPERTY OF H-J ENTERPRISES, INC. ANY REPRODUCTION IN PART OR AS A WHOLE WITHOUT THE WRITTEN PERMISSION OF H-J ENTERPRISES, INC. IS PROHIBITED.

TOLERANCES (EXCEPT AS NOTED)	
DECIMAL	+/- .032"/.8mm
FRACTIONAL	+/-
ANGULAR	+/- 2 Degrees



**H-J ENTERPRISES, INC.**  
3010 HIGH RIDGE BLVD. HIGH RIDGE, MO. 63049 USA  
PHONE 1-636-677-3421 FAX 1-636-376-1915

**STUD/CABLE CONNECTOR ASSEMBLY  
W/ 1 1/8-12UNF THREADS**

MATERIAL SEE DRAWING		DRAWING NO. <b>BDSC10-040TP</b>
CHK'D	APP'D 3/9/2015	
DRAWN BY CJT	DATE 2/8/01	SCALE N.T.S.