

REVISIONS					
REV.	DATE	ECN #	DESCRIPTION	BY	APPROVED

Ø 1.060" BUSHING HOLE
USE AS FURNISHED

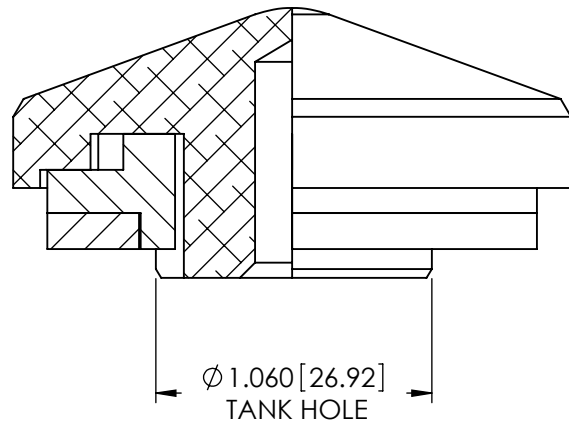

Ø 1.295" BUSHING HOLE
REMOVED TOP GASKET

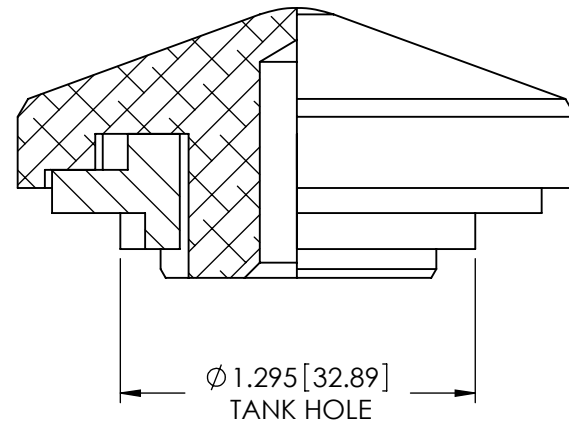

Ø 1.437" BUSHING HOLE
REVERSE MOLDED GASKET

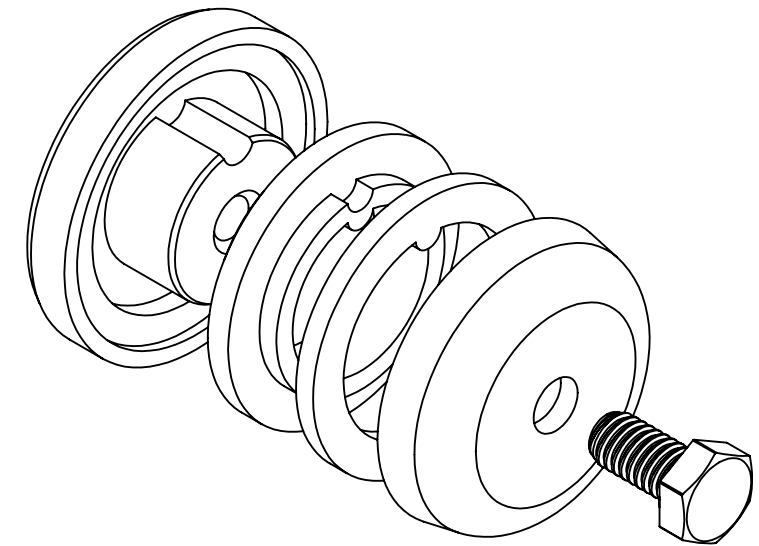
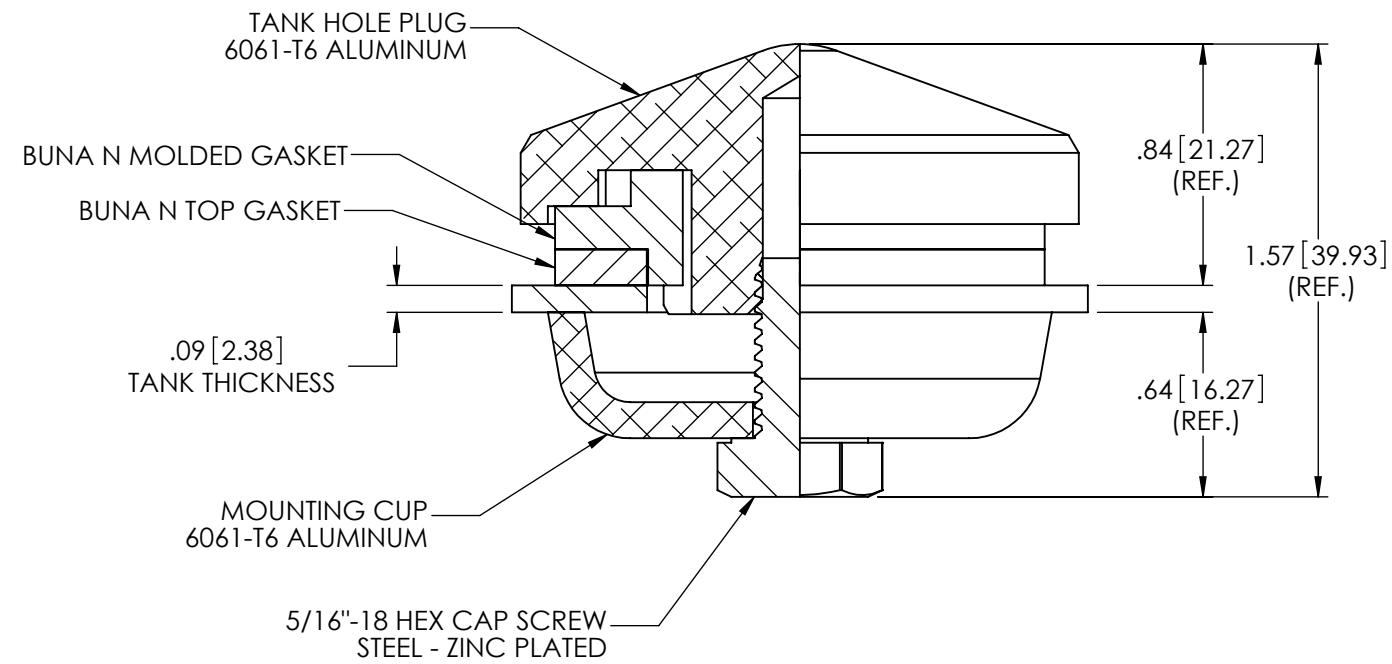
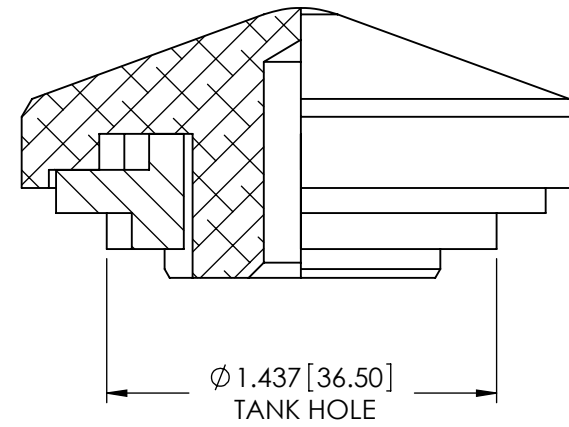

**TOLERANCES
(EXCEPT AS NOTED)**

DECIMAL	+/- .032"/.8mm
FRACTIONAL	+/-
ANGULAR	+/- 2 Degrees



H-J ENTERPRISES, INC.
3010 HIGH RIDGE BLVD. HIGH RIDGE, MO. 63049 USA
PHONE 1-636-677-3421 FAX 1-636-376-1915

3 IN 1 TANK PLUG

MATERIAL (SEE DRAWING)

CHK'D
SCALE N.T.S.

APP'D
SCALE N.T.S.

DRAWING NO.
AST1000-001

PROPRIETARY AND CONFIDENTIAL
THE INFORMATION CONTAINED IN THIS DRAWING IS THE SOLE PROPERTY OF H-J ENTERPRISES, INC. ANY REPRODUCTION IN PART OR AS A WHOLE WITHOUT THE WRITTEN PERMISSION OF H-J ENTERPRISES, INC. IS PROHIBITED.

DRAWN BY JH

DATE 5/5/2010