

REVISIONS					
NO.	DATE	ECN #	REMARKS	BY	APPD.
1	7-28-04	HJ04-130	REVISED HEX HEAD, AND A DIMENSION.	JRM	SP

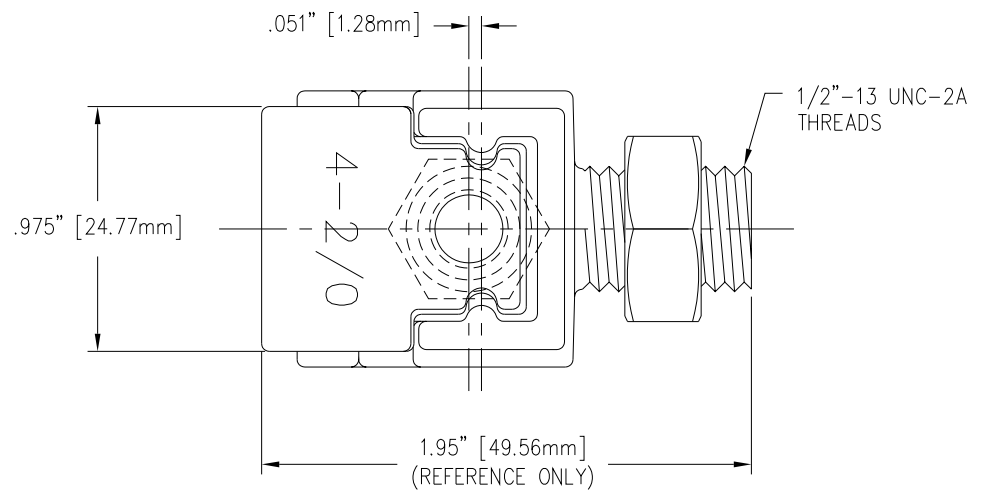
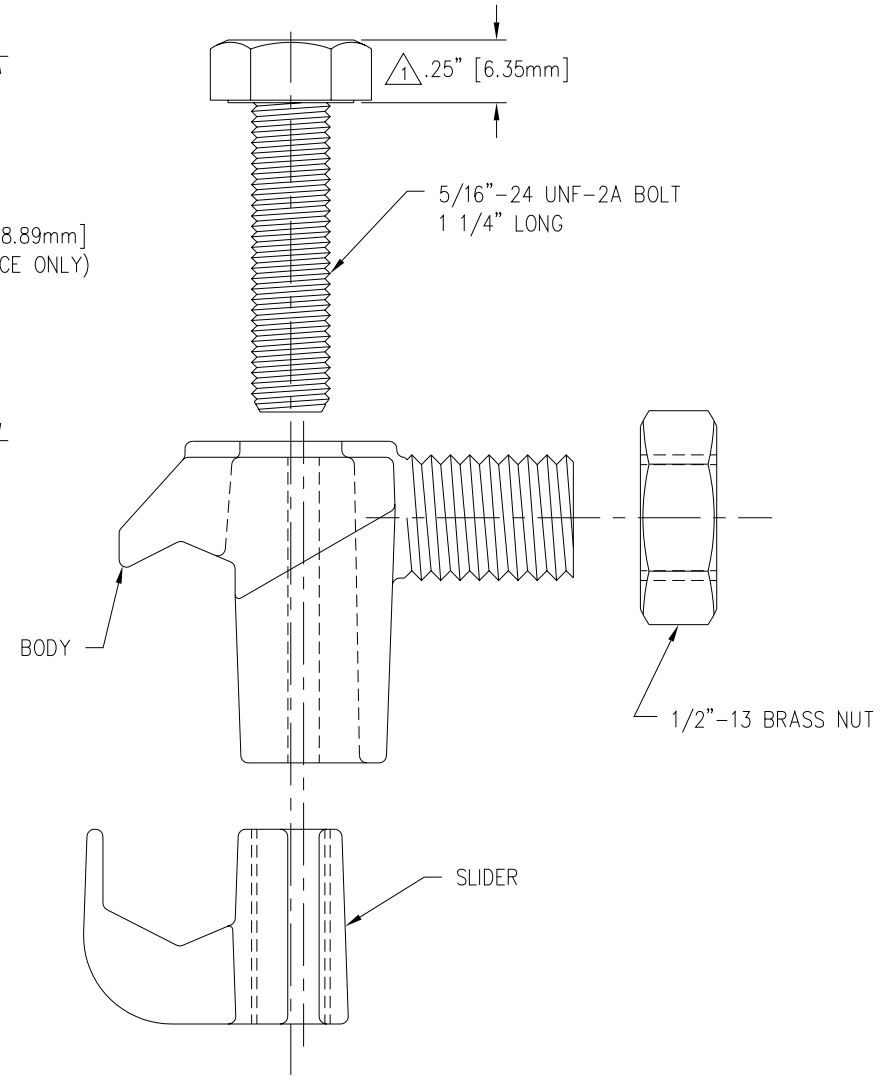
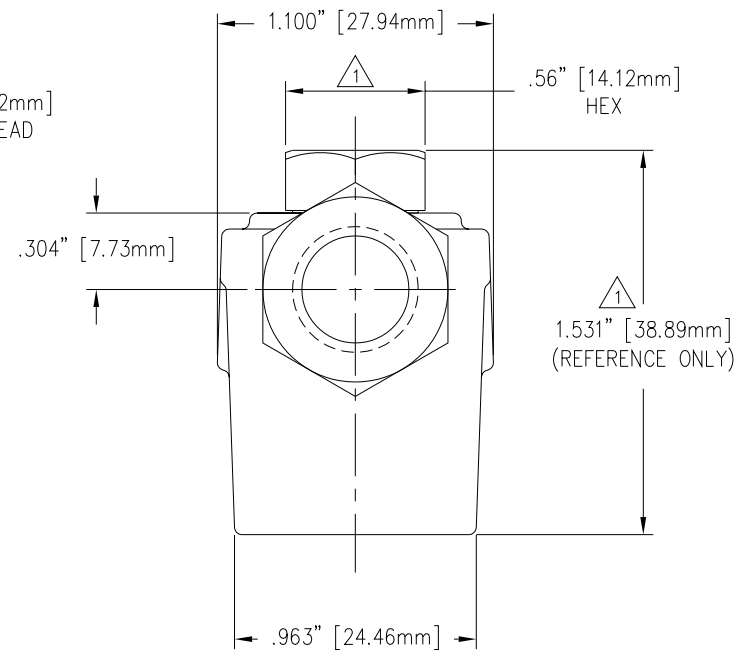
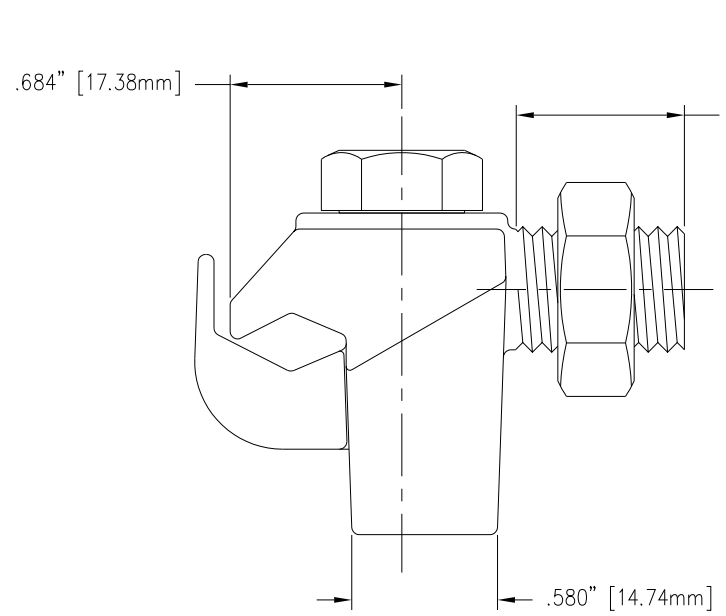

MATERIAL:
 BODY - CDA 95600 TIN PLATED
 SLIDER - CDA 95600 TIN PLATED
 BOLT - STAINLESS STEEL
 NUT - CDA 36000 BRASS FREE CUTTING

TOLERANCES (EXCEPT AS NOTED)				H-J ENTERPRISES, INC. 3010 HIGH RIDGE BLVD. HIGH RIDGE, MO. 63049 USA PHONE 1-636-677-3421 FAX 1-636-376-1915	
DECIMAL ± .032" / .8mm				WISE-TYPE CLAMP TANK GROUND ASSEMBLY #4-2/0	
FRACTIONAL ±		MATERIAL SEE DRAWING		DRAWING NO. AS1372-002	
ANGULAR ± 2°		CHK'D	APP'D	SCALE N.T.S.	
DRAWN BY CJT		DATE 6-4-01			