

REVISIONS					
NO.	DATE	ECN #	REMARKS	BY	APPD.
1	12-5-08	HJ08-240	CHANGED NUT MATERIAL.	CJT	JFS
2	08-13-13	HJ13-194	TERMINAL MATERIAL WAS C84400	CLS	BLB
3	05-28-14	HJ14-051	CHANGED TERMINAL BODY MATERIAL	CLS	BLB

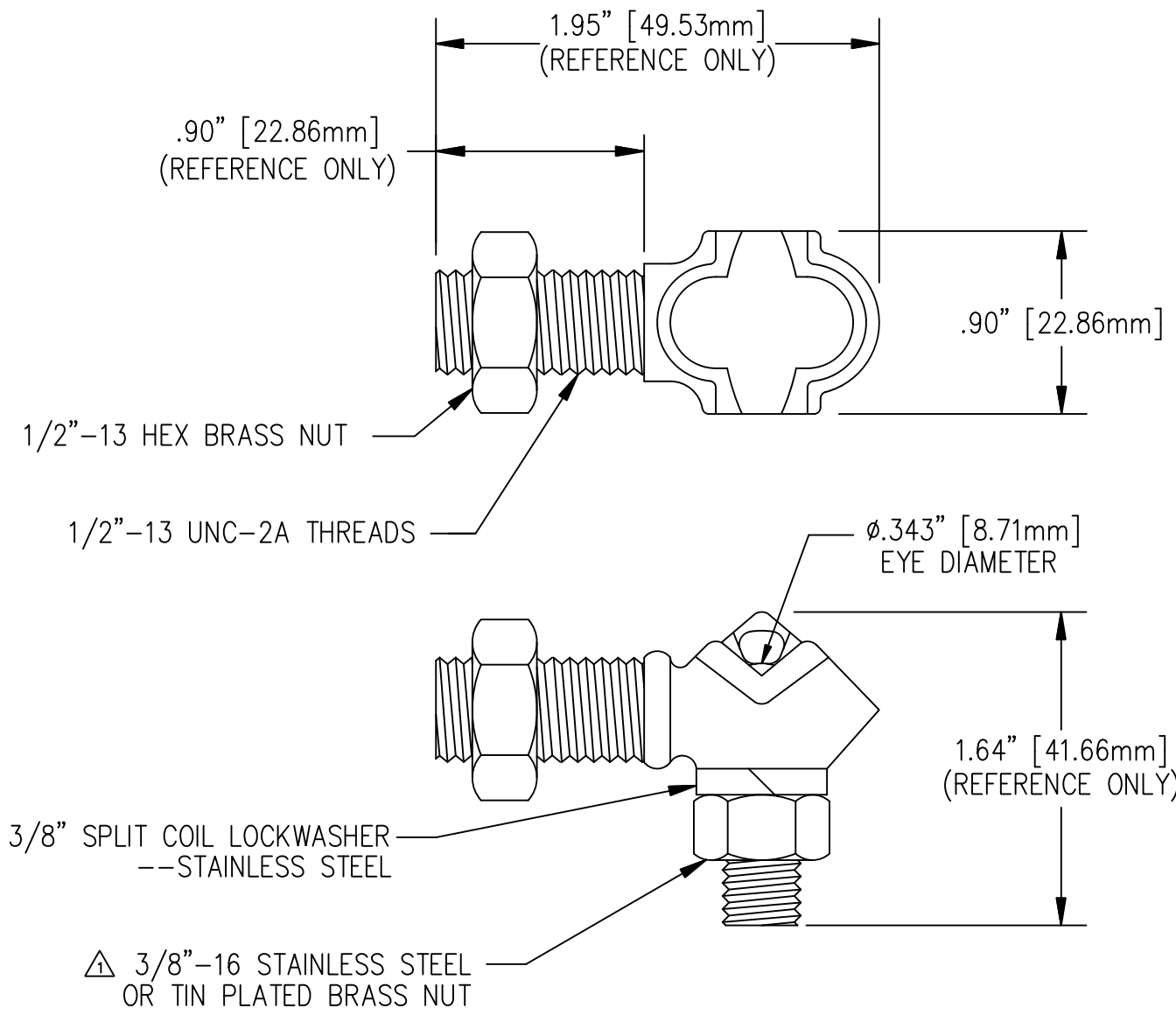

MATERIAL:
 BODY - BRASS TIN PLATED $\triangle 2$ $\triangle 3$
 EYEBOLT - C95500 TIN PLATED

TOLERANCES (EXCEPT AS NOTED) DECIMAL $\pm .032" / .8mm$ FRACTIONAL \pm ANGULAR $\pm 2^\circ$		H-J ENTERPRISES, INC. 3010 HIGH RIDGE BLVD. HIGH RIDGE, MO. 63049 USA PHONE 1-636-677-3421 FAX 1-636-376-1915	
		GROUND TERMINAL #10 STR.-#1 STR.	
		MATERIAL (SEE ABOVE)	
		CHK'D CJT	APP'D 05-28-14
DRAWN BY TLH	DATE 4-10-96	SCALE N.T.S.	